

Honeywell

ADEMCO VISTA-12A
ADEMCO VISTA-12E
Security Systems

Installation and Setup Guide

Table Of Contents

.....

Features and Installation Highlights	1-1
Capabilities	1-1
Functions	1-1
Compatible Devices.....	1-2
Important Installation Highlights (Installer Please Read)	1-2
Mounting and Wiring the Control.....	2-1
Cabinet and Lock	2-1
Mounting the PC Board.....	2-2
Wiring to Keypads	2-3
Sounder (Siren) Connections.....	2-5
Wiring the AC Transformer	2-5
Backup Battery	2-6
Earth Ground	2-6
Basic Wired Zones.....	2-8
Smoke Detectors	2-9
4219/4229 Expansion Zones	2-10
6164 Keypad Expansion Zones.....	2-11
Installing the RF Receiver.....	2-12
Installing a 5800TM Module.....	2-13
Installing the Transmitters.....	2-13
Installing a Keypad	2-14
Connecting Relay Modules	2-15
Powerline Carrier Devices.....	2-16
Trigger Module and On-Board Triggers	2-17
Phone Line Connections	2-18
Alternative Communications Media (ACM) Connections	2-18
Audio Alarm Verification Connections (AAV, "Listen-In")	2-19
Programming Overview	3-1
About Programming.....	3-1
Zones and Partitions.....	3-2
Keypads	3-3
Wireless Receiver Transmitters, and Wireless Keys (keyfobs).....	3-3
Pager Programming.....	3-4
Function Keys	3-4
Output Devices.....	3-4
Zone Type Definitions.....	3-5
Mechanics of Programming.....	3-8
Data Field Programming.....	4-1
About Data Field Programming	4-1
Programming Data Fields	4-1
System Setup Fields	4-1
Zone Sounds & Timing	4-3
Dialer Programming (*40 – *55).....	4-4

System Status Report Codes	4-7
Miscellaneous System Fields.....	4-9
Pager Programming Fields.....	4-13
Miscellaneous System Fields.....	4-15
AUI Enable.....	4-20
Keypad Programming Fields.....	4-20
Menu Mode Programming.....	5-1
About Zone Programming (*56 and *58 Menu Modes)	5-1
*56 Zone Programming Procedure	5-1
Completing Zone Programming	5-6
*58 Expert Programming Mode Procedures	5-7
Wireless Key Programming Templates	5-9
About Output Device Programming (*79/*80 Menu Mode)	5-13
*79 Menu Mode: Output Device Mapping	5-13
*80 Menu Mode: Defining Output Functions	5-15
About Zone Lists (*81 Menu Mode).....	5-18
Zone List Programming.....	5-19
About Function Key Programming (*57 Menu Mode).....	5-19
Programming Function Keys	5-20
About Descriptor Programming (*82 Menu Mode).....	5-21
Configurable Zone Type Programming (*83 Menu Mode)	5-22
Programming Installer and User Schedules	5-23
System Communication and Operation.....	6-1
Panel Communication with Central Station	6-1
Report Code Formats	6-1
Robofon 8 Format.....	6-4
ADEMCO Contact ID®.....	6-5
Security Codes.....	6-2
Keypad Functions	6-7
Panic Keys.....	6-9
Follow-Me Feature.....	6-10
Setting/Adjusting the Real-Time Clock	6-11
Various System Trouble Displays	6-12
Testing the System.....	7-1
About Test Procedures.....	7-1
System Test.....	7-1
Go/No Go Test Mode	7-2
Dialer Communication Test	7-3
Automatic Standby Battery Tests.....	7-3
Specifications & Accessories	8-1
SECURITY CONTROL.....	8-1
COMPATIBLE DEVICES	8-2
5800 Series Transmitter Input Loop Identification	8-3
Limitations and Warranty.....	9-1
Index	10-1

Features and Installation Highlights

.....

This manual describes the installation of both the VISTA-12A and VISTA-12E. These units are identical except where noted.

Capabilities

- Supports 2 independent partitions, which can protect two independent areas, as if each area had its own control.
 - Supports 1 common area partition that allows either of the other two independent partitions to arm, while leaving a common area (ex. lobby or foyer) disarmed for access into the remaining disarmed partition.
 - Supports up to 22 protection zones plus 16 keyfob zones (zones 49-64) for total of 38 zones:
 - 6 basic wired zones (zones 1-6) with optional zone-doubling/double-balanced zone feature
 - Up to 8 additional wired zones (zones 17-24) using an 8-zone 4219/4229 module.
 - Supports up to 16 wireless transmitter zones (5800 series; zones 9-24).
 - Supports up to 4 installer-configurable zone types
 - Up to 16 User Level Security Codes, each with separate authority levels and partition access
- Downloading: Via an IBM compatible computer, Compass downloading software, and an ADEMCO CIA/CIA-EU modem.

Functions

- Single-button arming feature: Can use dedicated keys to arm the system AWAY or STAY
- Up to 8 Schedules, to control output devices, to determine when users have access, and/or to auto-arm/disarm (or allow disarm) the system
- Up to 2 Keypad macros, which can be activated by wired/wireless keypads
- Paging feature allows certain system conditions to be reported to up to 2 pager phone numbers; can use a dedicated key on keypads to send a signal to a pager
- User programmable telephone number for audio "beeps" reporting of alarms to the user (follow-me feature).
- Built-in Telephone Line Monitoring option can monitor the telephone line voltage and can cause a local display, or a display and trouble/alarm sound.
- Event Logging records up to 254 selected events in a history log; control and readout from the log is done via ADEMCO Compass Downloader software or using an installer/master code at an alpha display keypad for local display.
- Installer-customized zone descriptors for all zones (useful only when using alpha display keypads).
- Optional siren supervision detects external sounder wiring short or open; causes a trouble condition, keypad display, and sends a report to the central monitoring station, if enabled.
- Optional RF jam detection for wireless systems detects a condition that may impede proper RF reception (i.e., jamming or other RF interference); causes keypad display, sends a report to the central monitoring station (if trouble reporting is enabled), and can optionally send a tamper alarm if detected during the armed mode.
- Individual user code selection for open/close reporting to central monitoring station (set when

adding a user code, attribute 6).

Compatible Devices

- Supports up to 8 Addressable Keypads: 6148/6150 Fixed-Word Display Keypads, 6164 Alpha Keypad, 6128RF/6128RFH/6150RF/6160RF Keypad/Transceivers, 6160V Voice Keypad
- Supports a 4219 or 4229 addressable basic wired zone expander module
- Supports 5881/5883 series receiver and 5800 series transmitters
- Outputs up to 4 relays, two on-board triggers, and/or Powerline Carrier Devices (X-10 type)
 - Use any combination of 4204, 4229, 6164 relays and/or Powerline Carrier Devices.
 - Output functions (up to 12)
- Alarm power output provides a 12VDC, 2 AMP output that can drive compatible sounders with a steady output for burglary/panic, or temporal pulse (3 pulses – pause – 3 pulses – pause – 3 pulses.) for fire. Uses current limiting circuitry for protection.
- Auxiliary Power Output: 12VDC, 700mA maximum, including output triggers.
- Backup Battery: Rechargeable (sealed lead-acid type) 12VDC, 6AH minimum.
- Audio Alarm Verification (using AAV module, such as ADEMCO UVS); can be used in conjunction with an output trigger to permit voice dialog between an operator at the central station and a person at the premises.
- Alternative Communication Media: Primary telephone number messages can be reported via ECP connection to Ethernet TCP-IP Internet/Intranet Network Modules, or other network interfaces (e.g., EUREKA)
- AC Power Supply:
 - VISTA-12A: Plug-in 230VAC power pack, XF1 Model No. 60844CK, Ap11V/99090/E148-36
 - VISTA-12E: 220VAC wired-in transformer, 16.5VAC 25VA

Important Installation Highlights (Installer Please Read)

- This system uses addressable keypads and a Zone Expander Module (see table of addresses in **Programming Overview** section).
- Keypads must be set for addresses 16-23 (first keypad is address 16, which is different from previous controls) and programmed in data fields *190-*196.
- Zone Expander Module must be set for specific address (08), based on the zone numbers used (see table of addresses in **4219/4229 Expansion Zones** section).
- 4204 Relay Module must be set for specific address (13; see **Connecting Relay Modules** section).
- 6164 Keypads must be set for two addresses: a keypad address and a zone expander address (if using the keypad's expansion zones).
- This control will not power-up unless AC mains is connected (will not power-up on battery alone). However, once the system is powered up, it will operate on battery power in the event of AC mains loss.
- Relays have two programming menu modes: Use *79 Menu mode to map module addresses and device (output) numbers. Use *80 Menu mode to define the output functions (see **Output Device Programming** section).
- This system supports programmable function keys. Use *57 Menu mode to define the function keys (see **Function Key Programming** section).
- This system provides various paging features. Refer to the **Programming Overview** section

for a summary on pager programming.

Mounting and Wiring the Control

This section describes the procedures for mounting and wiring this control and its peripheral devices. In the following subsections, procedures are listed in the left column, while notes and pertinent explanations are provided in the right column.

Cabinet and Lock

1. Mount the control cabinet to a sturdy wall in a clean, dry area, which is not readily accessible to the general public, using fasteners or anchors (not supplied) with the four cabinet mounting holes.
2. Remove cabinet door, then remove the lock knockout from the door. Insert the key into the lock.
3. Position the lock in the hole, making certain that the latch will make contact with the latch bracket when the door is closed. When correctly positioned, push the lock until it is held securely by its snap tabs.

Notes

- The cabinet can be closed and secured without a lock by using 2 screws in the cover's edge.

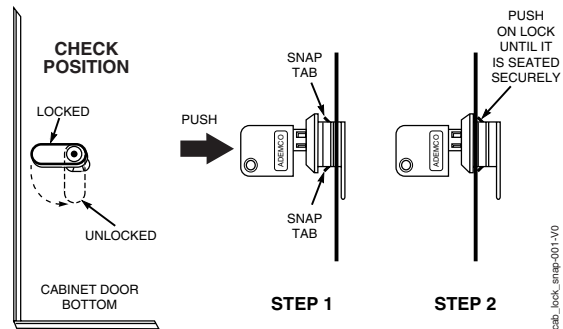

Figure 1. Installing the Cabinet Lock

Mounting the PC Board

NOTE: The door of the metal cabinet may be removed to make it easier to install the PC board. Remove the door as follows:

1. With the cabinet laying on a flat surface, swing open the door to its full-open position.
2. Slide the door out of its retaining slots in the cabinet and store in a safe place.
3. Remove standoff (part number K0380) from the hardware bag and insert it into the square hole in the back of the cabinet so that it will align behind the lower left mounting hole in the PC board.
4. Insert top of circuit board into slots at top of cabinet. Make sure that circuit board rests in slots as indicated in the diagram shown below.
5. Swing base of circuit board onto the raised cabinet tab and standoff.
6. Secure the sides of the PC board to the enclosure using the 2 screws provided.

Notes

- Before installing the cabinet's contents, remove the metal cabinet knockouts required for wiring entry. Do not remove the knockouts after the circuit board has been installed.

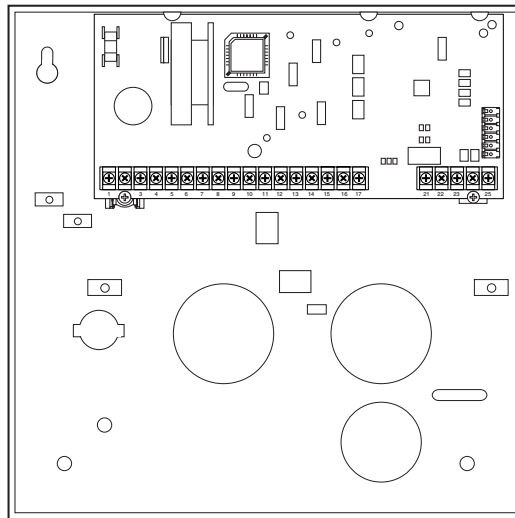

Figure 2. Mounting the PC Board

Wiring to Keypads

1. Connect keypads to the control's keypad terminals as shown on the Summary of Connections diagram. Determine wire size using the Wiring Run Chart below. If power supervision is required, refer to the **Aux Power Supervision Connections** paragraph at right.
2. Set keypad addresses. Refer to the address setting instructions included with the keypads and set each keypad device address according to the chart at right.
3. Program the keypad addresses, partition assignments and sound options in data fields *190-*196.

NOTE: Each keypad must be assigned a unique address, **starting at address 16**. Keypads programmed with the same address will give unpredictable results.

Supplementary Power (optional)

1. Connect as shown. Be sure to connect the negative (-) terminal on the power supply unit to terminal 4 (AUX -) on the control.

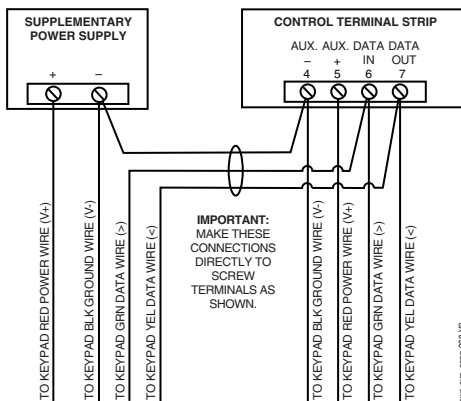

Figure 3. Using a Supplementary Power Supply

Notes

- Typical Fixed-Word Display: 6128RF/6148/6150/6150RF/6150V
- Typical Alpha Display: 6160/6160V/6164
- The system supports up to 8 keypads, which can be assigned to partitions in any combination (see program fields *190-*196).
- For single 4-wire runs, determine the current drain of all units, then refer to the Wiring Run chart to determine the maximum length that can be safely used for each wire size.
- Use supplementary power if the control's aux. power load for all devices exceeds 700mA. Suggested power supply: AD12612

Aux Power Supervision Connections

To supervise aux power:

1. Use the Trigger Module terminals for ground and +12V connections (instead of main board terminals 4 and 5). See **Trigger Module and On-Board Triggers** section (page 2-17) for instructions on mounting the Trigger Module.
2. Connect the SUPV terminal to a zone (+) terminal.
3. Program that zone as a configurable zone type programmed as a 24-hour zone and with the desired report code (CID code 312 is recommended).

Keypad Addresses

Keypad	Address	Keypad	Address
no. 1	16**	no. 5	20
no. 2	17	no. 6	21
no. 3	18	no. 7	22
no. 4	19	no. 8	23

** The first keypad is address 16, which is always enabled and set for partition 1 with all sounds on.

	<p>Keypads powered from supplies that do not have a backup battery will not function if AC mains power is lost. Make sure to power at least one keypad in each partition from the control's auxiliary power output.</p>
---	---

Wiring Run Chart For Devices* Drawing Aux Power From The Control (12V+ & 12V-)					
Wire Size	TOTAL CURRENT DRAIN OF ALL DEVICES CONNECTED TO A SINGLE WIRE RUN				
	50mA or less	100mA	300mA	500mA	600mA
0.6mm O.D.	152m	76m	24m	15m	13m
0.8mm O.D.	228.6m	116m	40m	24m	20m
1mm O.D.	396m	198m	67m	40m	35m
1.2mm O.D.	457m	305m	100m	70m	52m

* Includes Keypads, RF Receivers, Zone Expander/Relay Units, or TeleCommand Phone Module.

Maximum wire lengths for any device that is wired directly to the control can also be determined from the Wiring Run Chart, based on the current drain of that device alone.

The length of all wire runs for all partitions combined must not exceed 457m when unshielded quad conductor cable is used (228m if shielded/screened cable is used). This restriction is due to the capacitive effect on the data lines when quad cable is used.

Sounder (Siren) Connections

1. Make sounder connections to alarm output terminals 3 (+) and 4 (-).
For supervised output, continue with steps 2 and 3.
2. Cut the red Siren Supervision Jumper located above terminals 2 and 3 on the control board.
3. Connect a 2k ohm resistor across the terminals of the last sounder.

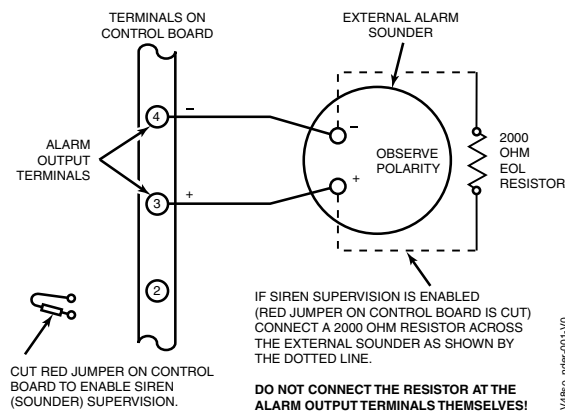

Figure 4. Sounder Wiring (Supervised)

Notes

- 2-5** The 12VDC sounder output activates when an alarm occurs.
- Total current drain from this output cannot exceed 2 amps (going beyond 2 amps will overload the power supply, or may cause the electronic circuit protecting the sounder output to activate).
 - You must install a battery, since the battery supplies this current.
 - Do NOT perform steps 2 and 3 if using a self-activated siren.

Wiring the AC Transformer

Transformer:

Connect the Transformer to terminals 1 and 2 on the control board. See wiring table at bottom of page for wire size to use.

Use wired-in or plug-in 110 (e.g., 1321)/220VAC transformer, with 16.5VAC, 25VA output.

VISTA-12A: XF1 Model 60844CK, Ap11 V/99090/E148-36

Using Powerline Carrier (X-10) Devices

If using Powerline Carrier (X-10) devices, a separate powerline modulator must be used, which is connected to the supplied Trigger Module via an SA4120XM-1 cable. See your local distributor for available modulators and connecting cable.

Notes

- Use caution when wiring the transformer to the control to guard against blowing the transformer fuse (the fuse is non-replaceable).
- Wiring to the AC transformer must not exceed 76m using 1.2mm O.D. wire. The voltage reading between terminals 1 and 2 of the control must not fall below 16.5VAC or an "AC LOSS" message will be displayed.
- Do not connect to AC mains power while making any wiring connections to the control. As a safety precaution, always power down the control when making such connections.

Wiring Table

Distance from control	Wire Gauge
Up to 15m	0.8mm O.D.
15-30m	1.0mm O.D.
30-76m	1.2mm O.D.

Backup Battery

1. Place the 12-volt backup battery in the cabinet.
2. After all connections to the control are completed and AC mains power has been applied, connect the red and black flying leads on the control board to the battery. Do not attach these leads to the battery terminals until all connections are completed.

Battery Saver Feature: The battery will disconnect from the system after its voltage decreases below 9VDC. This assists the control panel in recharging the battery when AC is restored.

Notes

IMPORTANT: The panel will not power up initially on battery power only. You must plug the transformer in first, and then connect the battery.

Operating on Battery Power Alone:

To operate the control on battery power only, connect a jumper between the negative (–) battery terminal and control PCB terminal 4 (– aux power).

Earth Ground

Metal Cold Water Pipe or Earth Ground Rod:

Use a non-corrosive metal strap (copper is recommended) firmly secured to the pipe/rod to which the ground lead is electrically connected and secured.

Notes

- This product has been designed and tested to ensure its resistance to damage from generally expected levels of lightning and electrical discharge, and does not normally require an earth ground.
 - If an earth ground is desired for additional protection in areas of severe electrical activity, terminal 25 on the control board, or the cabinet, may be used as the ground connection point. The examples of good earth grounds listed at the left are available at some installations.
-

AUXILIARY DEVICE CURRENT DRAIN WORKSHEET

DEVICE	CURRENT	# UNITS	TOTAL CURRENT
6128RF Keypad/Transceiver	90mA standby/120mA alarm		
6150RF Keypad/Transceiver	80mA standby/105mA alarm		
6148 Fixed-Word Keypad	30mA standby/55mA alarm		
6150 Fixed-Word Keypad	40mA standby/90mA alarm		
6160 Alpha Keypad	40mA standby/150mA alarm		
6150V Fixed-Word Display Voice Keypad	60mA standby/160mA alarm		
6160V Alpha Display Voice Keypad	60mA standby/190mA alarm		
6164 Keypad w/4-Zone Expander and Relay	115mA standby/190mA alarm		
5881 RF Receiver	35mA		
5883 RF Transceiver	80mA		
4219 Zone Expander	35mA		
4204 Relay Unit	15/180mA‡		
4229 Zone Expander/Relay Unit	35/100mA‡		
TeleCommand	55mA (standby) 119mA (local phone) 85mA (remote phone)		
*			
*			
TOTAL =			
(Current available from Aux. terminals = 700mA max.)			

*If using wired devices such as PIRs or Dual Tecs, refer to the specifications for that particular unit's current drain.

‡Figures are for relays OFF/relays ON.

Basic Wired Zones

Normally Open Zones/Normally Open EOLR Zones

1. Connect open circuit devices in parallel across the loop; for EOLR zones, connect the EOLR across the loop wires at the last device.
2. Enable normally open/EOLR zones using Zone Programming mode, “Hardwire Type” prompt.

Normally Closed Zones/Normally Closed EOLR Zones

1. Connect closed circuit devices in series in the high (+) side of the loop; for EOLR zones, connect the EOLR in series following the last device.
2. Enable normally closed/EOLR zones using Zone Programming mode, “Hardwire Type” prompt..

Double-Balanced: Connections as shown (resistors provided for one device in selected models); maximum of 8 sensors on each double-balanced zone.

IMPORTANT: Double-balanced zones provide unique tamper signaling on the same 2 wires used for alarm signaling, and should be used as burglary or emergency zones only. Do not use double-balanced zones as fire zones.

Zone Doubling: Connections as shown (resistors provided).

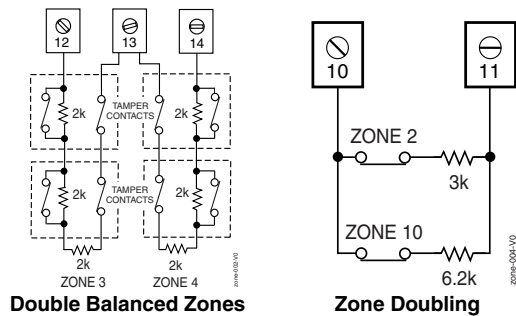

Figure 5. Configuring Zones

Notes

- **EOLR:** If the EOLR is not at the end of the loop, the zone is not properly supervised and the system may not respond to an “open” on the zone.
- Zone 1 is intended only for EOLR usage.

Zone Doubling:

This feature provides two unique zone identifications for normally closed sensors connected to each basic wired zone (but does not increase the total number of zones supported by the control). Do not use zone doubling for fire zones. If enabled (Zone Programming mode, “Hardwire Type” prompt, option “3”), basic wired zones are automatically paired as follows:

Zone zone	Paired with
1	9
2	10
3	11
4	12
5	13
6	14

NOTE: A short across the EOL (i.e., at terminal) on either zone of a zone-doubled pair or on a double-balanced zone causes a tamper condition (displayed at keypad as CHECK).

Smoke Detectors

4-Wire Smoke Detectors

Connect 4-wire smoke detectors (up to 16, depending on detector current drain) to any zone from 2-8 as shown on the next page. This control does not automatically reset power to 4-wire smoke detector zones, so you must use a relay (e.g., 4204, 4229), or on-board trigger 17 to reset power (also required for fire verification). Do this by programming the designated relay/trigger as zone type 54 (fire zone reset); see On-Board Trigger section for other information.

Notes

- **Fire Verification (zone type 16):** The control panel will “verify” a fire alarm by resetting the smoke detectors after the first alarm trigger, and then waiting 90 seconds for a second alarm trigger. If the smoke detector does not trigger again, the control will disregard the first trigger, and no alarm signal will occur. This feature eliminates false alarms from smoke detectors due to electrical or physical transients.
- Maximum current for trigger 17 output for 4-wire smoke detectors is 300mA.

Figure 6. 4-Wire Smoke Detector Connections

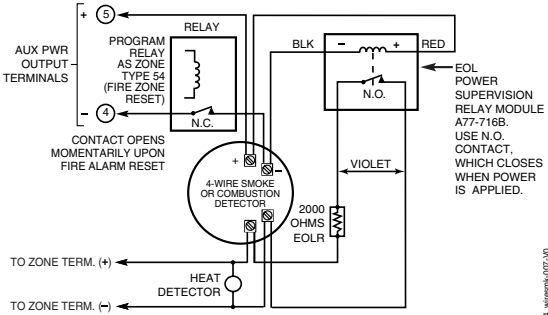

4-Wire Smoke Detector Using Relay for Power Reset

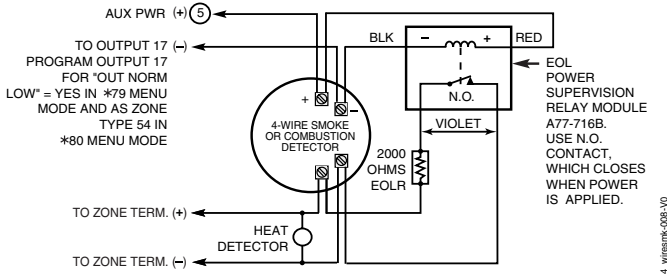

4-Wire Smoke Detector Using Output 17 for Power Reset

4219/4229 Expansion Zones

1. Connect each module to the control's keypad terminals.
If power supervision is required, use the Trigger Module terminals as described in the **Aux Power Supervision Connections** paragraph in the **Wiring to Keypads** section (page 2-3).
2. Assign the module a device address of 08 using its DIP switches. The device address determines the zone numbers being used, as shown below.

Expander Module Addresses

Zones...	Device Address...
17-24	08

3. Connect sensors to the module's loops.
4. If using relays with the 4229, connect the desired field wiring to the unit's relay contact terminals.

Notes

- Supports up to 8 expansion zones (NO or NC) using 4219/4229 Zone Expander Modules as follows:
- Use 1000 ohm end-of-line resistors at the end of loops connected to the 4219/4229 modules. (End-of line resistors used on the control terminals are 2000 ohms.)
- Expansion zones have normal response time (400–500 msec), except zone connected to each module's loop "A," which can be set for fast response (10–15 msec).

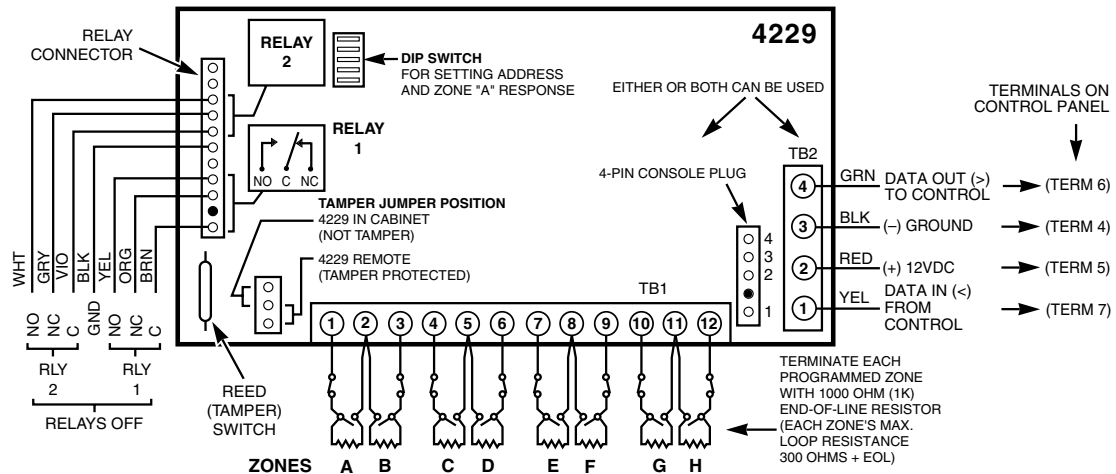

Figure 7. Wiring Connections, 4219 & 4229 (4229 shown)

4229-002-V0

6164 Keypad Expansion Zones

1. Connect each keypad to the control's keypad terminals.
If power supervision is required, use the Trigger Module terminals as described in the **Aux Power Supervision Connections** paragraph in the **Wiring to Keypads** section (page 2-3).
2. Using the keypad's program mode, assign the keypad a unique keypad address (16-23), and assign a device address of 08 that provides expansion zones 17-20.
3. Connect sensors to the keypad's zone terminals.
4. If using the keypad relay, connect the desired field wiring to the keypad's relay contact terminals.
See 6164 Keypad Instructions for other mounting, wiring, and programming information.

Notes

- Each 6164 keypad supports up to 4 wired expansion EOLR or double-balanced zones and one relay output.
- Use 2000 ohm end-of-line resistors at the end of loops connected to the 6164 keypads.

- Enter 6164 keypad program mode by pressing and holding down both the [1] and [3] keys within 60 seconds of power up.
- Enable the keypad addresses using data fields *191-*196 as required.
- Program keypad zones using *56 Menu mode. Keypad zones 1-4 correspond to the respective groups of zones shown in the chart at left, where keypad zone 1 is the lowest zone number in each group.

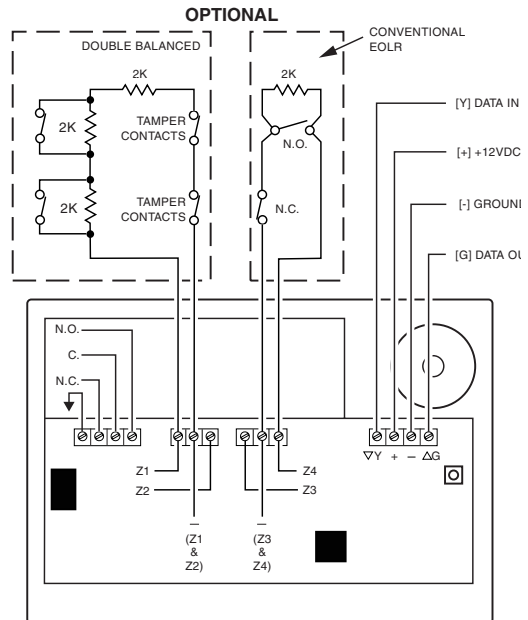

Installing the RF Receiver

Use one of the following receivers:

RF Receiver	Number of Zones
5881ENL (buttons)	up to 8 (including keyfob buttons)
5881ENM (buttons)	up to 16 (including keyfob buttons)

1. Set Device Address to "00" as described in its instructions (set all switches to the right, "off" position).
2. Mount the receiver, noting that the RF receiver can detect signals from transmitters within a nominal range of 67m.
3. Connect the receiver's wire harness to the control's keypad terminals. Plug the connector at the other end of the harness into the receiver. Refer to the installation instructions provided with the receiver for further installation procedures regarding antenna mounting, etc.

If power supervision is required, use the Trigger Module terminals as described in the **Aux Power Supervision Connections** paragraph in the **Wiring to Keypads** section (page 2-3).

Notes

- The receiver is supervised and a trouble report is sent ("CHECK 100" displayed) if communication between the panel and receiver is interrupted, or if no valid RF signals from at least one supervised transmitter are received within 12 hours.
- Only one receiver can be installed in a system.

If the receiver is mounted remotely:

- Place the RF receiver in a high, centrally located area for best reception.
- Do not locate the receiver or transmitters on or near metal objects. This will decrease range and/or block transmissions.
- Do not locate the RF receiver in an area of high RF interference (indicated by frequent or prolonged lighting of the LED in the receiver; random flicker is OK).
- Do not locate RF receiver closer than 3m from any keypads to avoid interference from the microprocessors in those units.

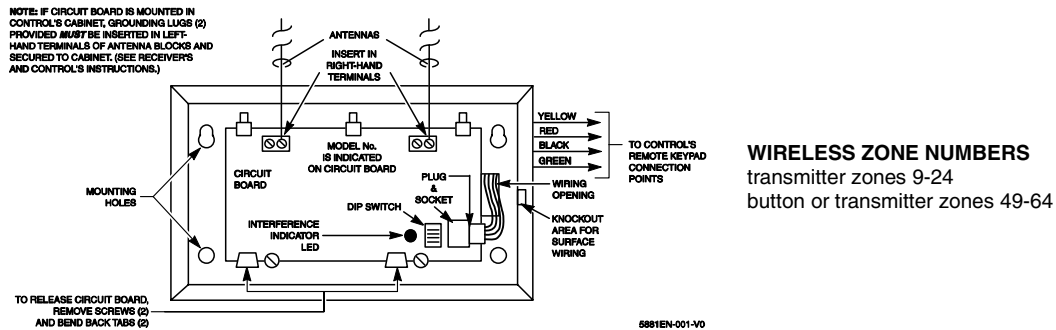

Figure 8. 5881EN RF Receiver (cover removed)

Installing a 5800TM Module

1. Mount the 5800TM next to the RF receiver (between one and two feet from the receiver's antennas) using its accompanying mounting bracket. Do not install within the control cabinet.
2. Connect the 5800TM to the control panel's keypad connection terminals as shown on the Summary of Connections diagram and set to address 28.

Notes

- Use this module only in 345Hz RF systems and if you are using one or more wireless bi-directional keypads or keyfob; 5800TM is not necessary if using a Transceiver (e.g., 5883).
- The 5800TM must be set to address 28 (cut red-W1 jumper).
- The 5800TM can be used in partition 1 only.
- For additional information regarding the 5800TM, refer to the 5800TM's instructions.

Installing the Transmitters

1. To be sure reception of the transmitter's signal at the proposed mounting location is adequate, perform a Go/No Go Test (see the **Testing the System** section).
2. Install transmitters in accordance with the instructions provided with each.
3. Set 5827, 5827BD, 5804BD wireless keypads to the programmed House ID (field *24), using its DIP switches (5827) or follow the instructions provided with the device.

Notes

- Refer to the table of compatible devices at the back of this manual.
- Supervised transmitters[†] send check-in signals to the receiver at 70-90 minute intervals. If at least one check-in message is not received from each transmitter within a 12-hour period, the "missing" transmitter number(s) and "CHECK" is displayed.

[†] Hand-held transmitters (e.g., 5802, 5802CP, 5804, 5804BD, 5827, 5827BD) do not send check-in signals.

Transmitter Battery Life

- See Wireless Transmitter paragraph in the *Limitations of This Alarm System* statement located at the end of this manual for information on transmitter battery life.
- Some transmitters (e.g., 5802 and 5802CP) contain long-life but non-replaceable batteries, and no battery installation is required. At the end of their life, the complete unit must be replaced (and a new serial number enrolled by the control).
- Button-type transmitters (such as 5801, 5802, and 5802CP) should be periodically tested for battery life.
- The 5802MN, 5802MN2, and 5804 Button Transmitters have replaceable batteries.

Do not install batteries in wireless transmitters until you are ready to enroll during system programming. After enrolling, batteries need not be removed.

Installing a Keyswitch

1. Connect the 4146 keyswitch's normally open momentary switch to a zone's terminals (zones 2-8). Remove the 2000 ohm EOL resistor if connected across the selected zone.
2. Using a standard keypad cable as shown: Connect the yellow and white keyswitch wires to trigger connector pin 3 (+12V). Connect the Red and Green LED wires to the appropriate output 17/output 18 trigger connector pins.
3. Connect a 2000 ohm EOL resistor across the momentary switch.
4. You can wire an optional closed-circuit tamper switch (model 112) in series with the zone. If the switch plate is then removed from the wall, the tamper will open, disabling keyswitch operation until the system is next disarmed from the keypad. If the tamper is opened when the system is armed, an alarm will occur.

Notes

- Use 4146 keyswitch or any normally open keyswitch.
- Use only one keyswitch per partition.
- If using a keyswitch in more than one partition, you must use relays (not the on-board triggers) for the Red/Green LED functions (step 2).

- When using a keyswitch, the zone it is connected to is no longer available for use as a protective zone.
- Use *56 Menu mode to program the keyswitch zone and assign it zone type 77.
- Use *80 Menu mode to program the LED functions: program outputs 17 and 18 for system operation zone type 78 (red LED) and 79 (green LED) as appropriate (see **Output Device Programming** section).

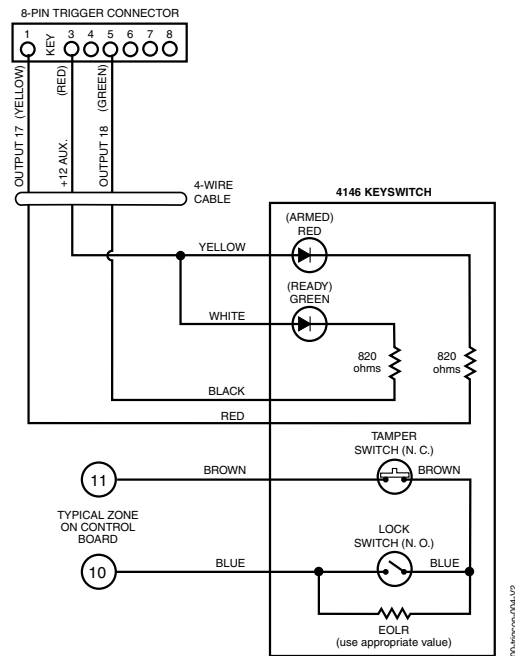

Figure 9. Keyswitch Wiring Connections

Connecting Relay Modules

1. Mount either remotely or in the control panel.
2. Connect to control's keypad terminals using the connector harness supplied with the module. Use standard 4-conductor twisted cable for long wiring runs.
If power supervision is required, use the Trigger Module terminals as described in the **Aux Power Supervision Connections** paragraph in the **Wiring to Keypads** section (page 2-3).
3. Set the module's device address according to the table at right.
4. Connect the desired field wiring to the unit's relay contact terminals.

Notes

- Use 4204/4229 modules or 6164 keypad.
- Supervision: 4204/4229 modules and 6164 keypad are supervised against removal. The module's device address is displayed as follows if a module is disconnected from the control's terminals, or if the module cover is removed and the tamper jumper is installed:
Alpha: CHECK xx Wire Expansion
FAULT xx Wire Expansion
TAMPER xx Wire Expansion
ALARM xx Wire Expansion

Fixed-Glass: lxx (or 91 if field *199 set for 2-digit display)
where "xx is the module's address.

- If communication/tamper failure occurs on a device with zones wired to it, all zones on the device will be displayed in their respective partitions.

Relay Module Addresses

4204/6164 [†]	Address	4229/6164 ^{††}	Address
2	13	(zn 17-24)	08

[†] Use these addresses if using only relays with the 6164 and not its zones.

^{††} Use these addresses if using zone expansion and relays with the 6164; supports only the first four zones in parenthesis.

NOTE: You can not use a 4229 and 6164 in the same system.

^{†††} Not available if zone doubling used.

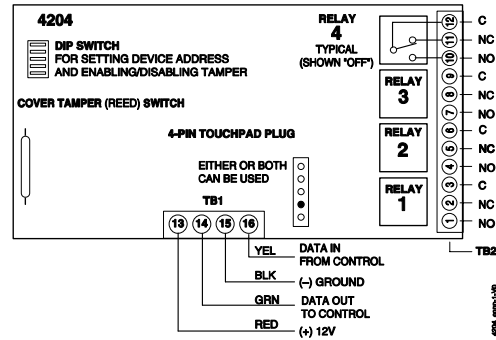

Figure 10. 4204 Connections to Control
(4229 Module connections and 6164 optional keypad connections are shown in the Expansion Zones section on pages 2-10 and 2-11, respectively)

Powerline Carrier Devices

1. Install up to 4 powerline carrier devices (if no relays are used) according to the instructions included with each.
2. Connect the Powerline Interface Modulator to the Trigger Module connector using SA4120XM-1 cable as shown below.
3. Use Programming Mode to enter the device house ID in data field*27, and enter the unit code using *79 Output Device menu Mode.

Notes

- When using Powerline Carrier devices, you must use a Powerline Carrier Device Modulator. It supplies signals from the control panel through the premises AC mains wiring to the Powerline Carrier devices (which are plugged into AC outlets). You can then make devices that are plugged into Powerline Carrier devices perform various functions in response to commands you enter at the security system keypads.

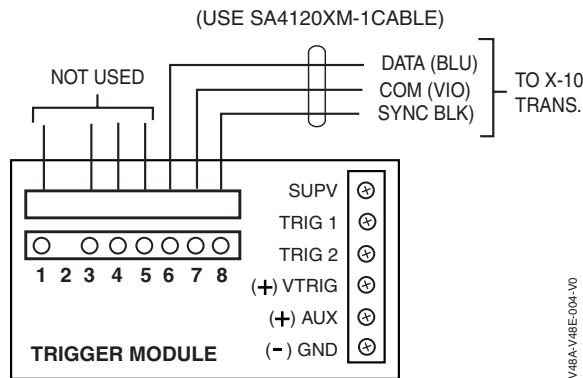

Trigger Module Powerline Interface Connections

Trigger Module and On-Board Triggers

IMPORTANT: Make all wiring connections to the Trigger Module **before** mounting the module to the PC board.

1. Connect field wiring to the desired trigger terminal on the trigger module (TRIG 1 = output 17; TRIG 2 = output 18) and the VTRIG +12V terminal.

For supervised trigger operation, refer to the following:

Trigger Voltage/Aux Power Supervision

To supervise trigger voltage and/or aux power:

- A. For Aux Power: Use the Trigger Module terminals for ground and +12V connections (instead of main board terminals 4 and 5).
For Trigger Voltage: Connect trigger wiring as described in step 1 above.
- B. Connect the SUPV terminal on the Trigger Module to a zone (+) terminal.
- C. Program that zone as a configurable zone type programmed as a 24-hour zone and with the desired report code (CID code 312 is recommended).

2. If using a Powerline Interface Modulator and powerline carrier devices, use the SA4120XM-1 cable (part of 4120TR Trigger Cable). See previous *Powerline Carrier Device* section.
3. Install the Trigger Module by aligning its 8-pin header over the main PC board's 8-pin connector (orient the Trigger Module as shown on the Summary of Connections diagram), then press down firmly until the Trigger Module's standoffs are seated on the main PC board.

Notes

- There are two on-board triggers that can be used to activate output devices.
- These outputs are normally high, and go low upon programmed condition.
- The outputs can be programmed for inverted operation (normally low, go high) using *79 Menu mode.
- Program these triggers using *80/*81 Menu modes as you would for any other relay output.
- When using these outputs, note:
 - pin 1 = output number 17 (trigger 1):
15 ohms to ground when closed (output low), open when off (output high, normal default); can be used to reset smoke detector power (must set "output normal low = yes" in *79 Menu mode, and set for zone type 54, fire zone reset, in *80 Menu mode); or can support 12V relay module that draws less than 300mA.
 - pin 5 = output number 18 (trigger 2):
15 ohms to ground when closed (output low); open when off (output high, normal default); or can support 12V relay module that draws less than 300mA.
- **NOTE:** Do not exceed 700mA combined current for both triggers and aux power. Doing so can damage PC board components and will void the system's warranty.

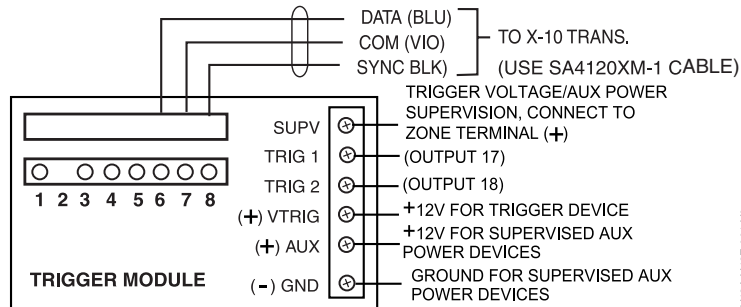

Figure 11. Trigger Module

Phone Line Connections

VISTA-12E

Connect incoming phone line and handset wiring to the main terminal block (via an RJ31X jack) as shown in the Summary of Connections diagram. Wire colors represent the colors of the cable to the RJ31X jack.

VISTA-12A

Plug the phone line plug into the modular phone connector mounted on the PC board.

Notes

- If you are using an Audio Alarm Verification (AAV) unit, refer to **Audio Alarm Verification (AAV)** section for special wiring connections.

CAUTION: To reduce the risk of fire, use only 0.6mm O.D. or larger telecommunication line cord for phone line connections.

Alternative Communications Media (ACM) Connections

Connect the data in/data out terminals and voltage input terminals of the ACM to the control's keypad connection points.

Set the ACM's address to "03" following the instructions provided with the ACM.

Notes

- Use compatible ACMs (e.g., 7845i, AI4164RS, or AI4164ETH).

Audio Alarm Verification Connections (AAV, "Listen-In")

Refer to the connection diagram below.
Connections use one of the on-board triggers.

Suggested AAV Module:
ADEMCO UVS (shown) or Eagle 1250

Notes

- Set field *91 for AAV and program the appropriate output (output 17 or 18) using *80 Menu mode (select zone type "60").
- For voice session monitoring, connect an EOLR zone to UVCM module terminals 6 & 7, and program the zone as zone type 81 (*56 Menu mode).

E.g., Using output 18 for the trigger,
program an output function in *80 Menu mode as:
ZT = 60, P = 0, Action = 1, Device = 18

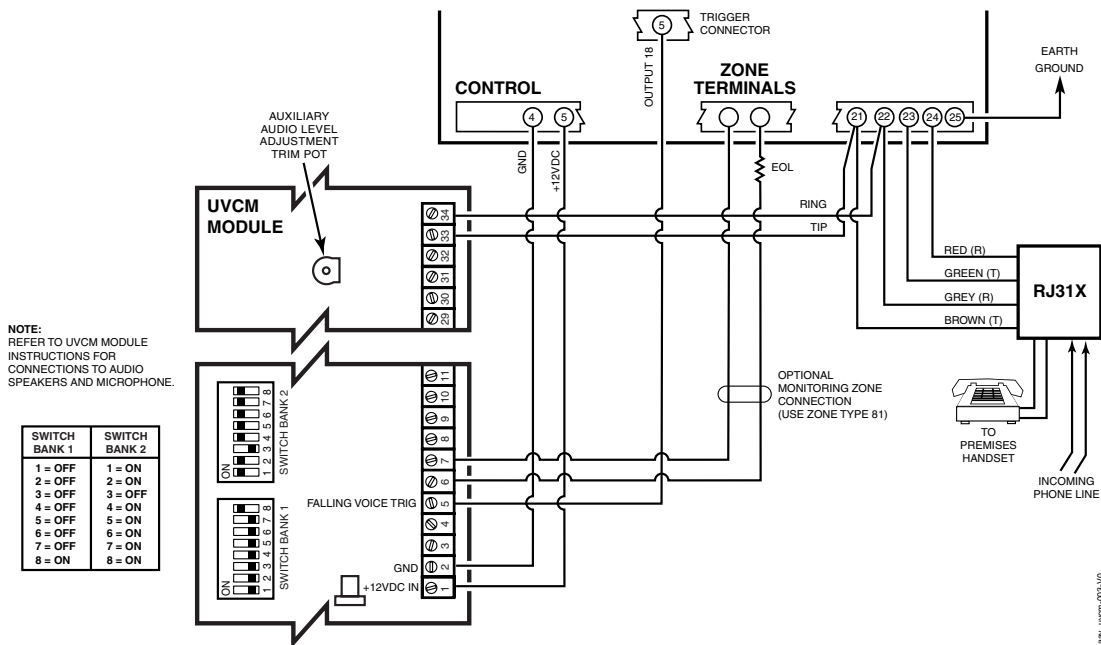

Figure 12. Connection of AAV Unit

Programming Overview

About Programming

You can program the system at any time, even at the installer's premises prior to the actual installation. Programming can also be performed remotely from the installer's office/home, using an IBM compatible personal computer, a CIA/CIA-EU modem, and Compass downloading software.

The following is a list of the various Programming modes used to program this system:

Programming Mode...	Used to ...
Data Field Programming	Program basic data fields used for setting the various system options. Most of the data fields in this system have been programmed for specific default values. However, some fields must be programmed for each particular installation to establish its specific alarm and reporting features.
*56 Zone Programming	Assign zone characteristics, report codes, alpha descriptors, and serial numbers for RF transmitters.
*57 Function Key Programming	Program each of the four function keys to perform one of several system functions.
*58 Zone Programming (Expert Mode)	Assign zone attributes similar to *56 mode, but provides a faster programming procedure and is intended for those more experienced in programming controls of this type.
*79 Output Device Mapping	Assign device addresses used by 4229/4204 Relay modules or 6164 keypad and map specific relays and device outputs, and assign unit codes for Powerline Carrier devices
*80 Output Definitions	Define up to 12 output definitions which can control the output relays mapped using *79 Output Device Mapping mode.
*81 Zone List Programming	Create Zone Lists for relay/powerline carrier zones, chime zones, night-stay, exit route zones, final exit door zone, and pager zones.
*82 Alpha Programming	Create alpha descriptors for easy zone identification.
Scheduling Mode (code + [#] +64)	Create schedules to automate various system functions or determine user access.

Zones and Partitions

Each protection zone needs to be programmed with various attributes using *56 Zone Programming mode or *58 Expert Programming mode. Refer to those sections for detailed procedures.

The system can control three independent areas of protection (known as partitions) for use by independent users, if desired.

Partitioning involves simply assigning zones to one of the three partitions during zone programming:

- The user's partition number can be displayed on keypads by enabling data field *198.
- The system, by default, automatically distributes users among the three partitions.
- The master user can change the user number distributions.
- Zones can also be assigned to a common area partition if partition 3 is so designated, which is an area shared by users of the other two partitions (such as a lobby in a building).
- Common area partition allows either of the independent partitions to arm, while leaving the common area partition disarmed for access into the other partition.
- The following describes the functioning of the common area partition, if used:
 - The common area sounds and reports alarms only when both the other partitions are armed. If only one partition is armed, the system ignores faults in the common area.
 - Either partition may arm its system if the common area is faulted, but once armed, the other partition will not be able to arm unless the common area zones are first bypassed or their faults are corrected.
 - Faults in the common area are displayed on common area keypads, and will also appear on another partition's keypad when that partition is armed.
- Either partition can clear and restore the common area after an alarm.

Keypads

Keypads are identified by predefined addresses (starting at address 16) as follows:

Address	Keypad	Program Field
16	keypad 1	• always enabled for partition 1, all sounds enabled.
17	keypad 2	• data field *190
18	keypad 3	• data field *191
19	keypad 4	• data field *192
20	keypad 5	• data field *193
21	keypad 6	• data field *194
22	keypad 7	• data field *195
23	keypad 8	• data field *196

NOTE. First keypad is address 16

To enable keypads:

1. Set desired address at keypad (refer to keypad's instructions for setting the address).
2. Use data field program mode to enable keypad addresses, assign a partition, enable sound options in fields *190-*196 as shown in the table above.
3. If desired, use data field *198 to turn on the display of the partition number.
4. Set the following keypad-related data fields as required by the installation:

*21 Quick Arm Enable	*180 Zone Bypass Limit
*23 Forced Bypass	*186 Display Options
*25 Arming Prevention Override	*188 Keypad Sabotage Options
*84 Auto STAY Arm [†]	*197 Exit Time Display Interval
*86 Exit Options	[†] NOTE: Do not use this option if Telecommand is installed to permit remote end-user control of the system.

Wireless Receiver Transmitters, and Wireless Keys (keyfobs)

Receiver: Set the receiver's address to "00" using its DIP switches, then set the following options:

- *22 RF Jam Option
- *24 RF House ID Code (if using DIP switch equipped wireless keypads) for each partition
- *25 Arming Prevention Override
- *67 Transmitter Low Battery Report Code
- *75 Transmitter Low Battery Restore Report Code
- *173 RF Reporting Options
- *178 RF Supervision/RF Jam Options

Use *56 Menu mode to program wireless zones 9-24 and wireless button zones 49-64.

Transmitters: Use *56 or *58 Zone Programming Menu modes to program zone information and enroll transmitters (zones 9-24, buttons 49-64).

Wireless Keys: Use Wireless Key Programming Templates section of the *58 Zone Programming Menu mode to program zone information and enroll each button of the wireless keys used. Once a wireless key is enrolled, it must be assigned to a user before it becomes active. See Adding/Deleting Security Codes section for procedure.

Pager Programming

The system can send various reports to up to 2 pagers.

To program pager reporting, do the following:

1. Enter the appropriate information in the following data fields:
 - *160, *163 Pager Phone Numbers (for pagers 1 and 2 respectively)
 - *161, *164, Pager Prefix Characters (for pagers 1 and 2 respectively)
 - *162, *165, Pager Reporting Options by Partition[†] (for pagers 1 and 2 respectively)
2. Enable Pager Delay, if desired, in field *166 (delays alarm reporting for ALL pagers).
3. Enable appropriate user open/close pager reports using the user attribute command (master code + [8] + user no. + [#] [5] + [1]). Users that perform actions in their assigned partition will, if enabled, attempt to report to all pagers enabled for open/close reporting in that partition.
4. If using child-not-home pager report, define the report schedule using Scheduling mode (master code + [#] [6] [4] then select event type "03").
5. If using a function key to manually send a message to a pager, see Function Keys paragraph below.
6. If reporting zone alarms and troubles to a pager, use *81 Zone List menu mode to assign the zones associated with each pager (zone lists 9-11).

Function Keys

To assign functions to the function keys, use *57 Function Key menu mode.

To assign emergency key functions (function key option "00"), first program the respective emergency zone number (95 for "A" key, 96 for "C" key, 99 for "B" key) with the desired zone type using *56 Zone Programming mode, then use *57 Function Key menu mode to assign the desired key.

If using a function key to activate a relay action (*57 Menu mode key function 07), use *79 Menu mode to map the output, and use *80 Menu mode to define the output's action; select system operation type "66."

If using a function key for a user macro, use *57 menu mode to activate the desired key, then define the actual macro functions using the user code + [#] + [6] [6] command.

Output Devices

To program a device for manual activation (user code + [#] [7] / [#] [8] + 2-digit device number) or for scheduled automatic activation, simply map the device using *79 Menu mode.

To program a device to automatically activate upon a system event (or function key), use *79 Menu mode to map the device, then use *80 Menu mode to define the automated device action.

If the device action is based on more than one zone, use *81 Zone List menu mode to assign the zones.

Zone Type Definitions

You must assign a zone type to each zone, which defines the way in which the system responds to faults in that zone. Zone types are defined below.

Zone Type	Description
Type 00: Zone Not Used	Program a zone with this zone type if the zone is not used.
Type 01 Entry/Exit Burglary #1	<ul style="list-style-type: none"> • Assign to zones that are used for primary entry and exit. • Provides entry delay when zone type is faulted if control is armed in the Away, Stay, or Night-Stay modes. • No entry delay provided when the panel is armed in the Instant/Maximum mode. • Entry delay #1 is programmable for each partition. • Exit delay begins whenever the control is armed, regardless of the arming mode selected, and is programmable for each partition. (If Final Contact Set exit option is selected in field *88, exit delay remains on indefinitely until the last zone in zone list 8 is restored; once the last zone is restored, exit delay is then 5 seconds.)
Type 02 Entry/Exit Burglary #2	<ul style="list-style-type: none"> • Assign to zones that are used for entry and exit and require more time than the primary entry/exit point. • Provides a secondary entry delay, in same manner as entry delay #1. • Entry delay #2 is programmable for each partition. • Exit delay is the same as described for Type 01.
Type 03 Perimeter Burglary	<ul style="list-style-type: none"> • Assign to all sensors or contacts on windows and infrequently used exterior doors. • Provides an instant alarm if the zone is faulted when the panel is armed in the Away, Stay, Night-Stay, Instant or Maximum modes.
Type 04 Interior Follower	<ul style="list-style-type: none"> • Assign to a zone covering an area such as a foyer, lobby, or hallway through which one must pass upon entry (to and from the keypad). • Provides a delayed alarm (using the programmed entry 1 time) if the entry/exit zone is faulted first. Otherwise this zone type gives an instant alarm. • Active when the panel is armed in the Away mode. • Bypassed automatically when the panel is armed in the Stay or Instant modes; if armed in Night-Stay mode, zones assigned to zone list 05 (night-stay zone list) are not bypassed when system armed in Night-Stay mode.
Type 05 Trouble when Disarmed/ Alarm when Armed	<ul style="list-style-type: none"> • Assign to a zone covering a sensitive area such as a stock room, drug supply room, emergency exit door, etc. • Can also be used with a sensor or contact for an area where immediate notification of an entry is desired. • Assign for use with sensor, device, or sounder tamper protection. • Provides an instant alarm if faulted when armed in the Away, Stay, Night-Stay, Instant or Maximum modes. • During the disarmed state, the system will provide a latched trouble sounding from the keypad (and a central station report, if desired).

Zone Type	Description
Type 06 24-hour Silent Alarm	<ul style="list-style-type: none"> • Usually assigned to a zone containing an emergency button. • Sends a report to the central station but provides no keypad display or sounding.
Type 07 24-hour Audible Alarm	<ul style="list-style-type: none"> • Assign to a zone that has an emergency button. • Sends a report to the central station, and provides an alarm sound at the keypad, and an audible external alarm.
Type 08 24-hour Auxiliary Alarm	<ul style="list-style-type: none"> • Assign to a zone containing an emergency button, or to a zone containing monitoring devices such as water or temperature sensors. • Sends a report to the central station and provides an alarm sound at the keypad. (No siren output is provided.)
Type 09 Supervised Fire	<ul style="list-style-type: none"> • Provides a fire alarm on short circuit and a trouble condition on open circuit. A fire alarm produces a pulsing siren output. • This zone type is always active and cannot be bypassed.
Type 10 Interior w/Delay	<ul style="list-style-type: none"> • Provides entry delay (using the programmed entry time), if tripped when the panel is armed in the Away mode. • Entry Delay 1 begins whenever sensors in this zone are violated, regardless of whether or not an entry/exit delay zone was tripped first. • Bypassed when the panel is armed in the Stay or Instant modes; if armed in Night-Stay mode, zones assigned to zone list 05 (night-stay zone list) are not bypassed when system armed in Night-Stay mode.
Type 12 Monitor Zone	<ul style="list-style-type: none"> • Works as a dynamic monitor of a zone fault/trouble (not alarm). In the case of a short/open, the message, "*ALARM*-24 Hr. Non-Burg. -#XXX " (where XXX is the zone number) will be sent to the Central Station. The system keypad will display a "CHECK" message indicating the appropriate zone (but keypad beeping does not occur). Upon restoral of the zone, the message, "*RESTORE*-24 Hr. Non-Burg. -#XXX " will be sent to the Central Station. • The "CHECK" message will automatically disappear from the keypad dynamically, when the zone restores; a user code + off sequence is not needed to reset the zone. • Faults of this zone type are independent of the system, and can exist at the time of arming without interference. • Since this is a "trouble" zone type, do not use this zone type with relays set to activate upon "alarm."
Type 14 24 Hour Gas Monitor	<ul style="list-style-type: none"> • Assigned to any zone with a gas detector. • The siren output will pulse when this zone type is alarmed. • Always active and cannot be bypassed.
Type 16 Fire w/Verification	<ul style="list-style-type: none"> • Provides a fire alarm when zone is shorted, but only after alarm is verified. • System verifies alarm by resetting zones for 12 seconds after short is detected. A subsequent short circuit within 90 seconds triggers fire alarm. • Provides a trouble response when zone is open.

Zone Type	Description
Type 20: Arm-Stay (BR RF devices only)	<ul style="list-style-type: none"> Arms the system in Stay mode when the zone is activated. Pushbutton units send user number to the central station when arming/disarming. User number for button must be assigned.
Type 21: Arm-Away (BR RF devices only)	<ul style="list-style-type: none"> Arms the system in Away mode when the zone is activated. Pushbutton units send user number to the central station when arming/disarming. User number for button must be assigned.
Type 22: Disarm (BR RF devices only)	<ul style="list-style-type: none"> Disarms the system when the zone is activated. User number for button must be assigned.
Type 23 * No Alarm Response	<ul style="list-style-type: none"> Can be used on a zone when an output relay action is desired, but with no accompanying alarm (e.g., lobby door access). Zone faults/restores are event logged.

* The system can still be armed when these zone types are in a faulted condition.

Zone Type	Description
Type 24 Silent Burglary	<ul style="list-style-type: none"> Usually assigned to all sensors or contacts on windows and infrequently used exterior doors where siren sounding is NOT desired for alarms. Provides an instant alarm, with NO audible indication at any keypad or external sounder, if the zone is faulted when the system is armed in the Away, Stay, Instant, or Maximum modes. A report is sent to the central station.
Type 77 Keyswitch	<ul style="list-style-type: none"> Assign to zone wired to a keyswitch. Do not use devices assigned as input type "BR" with this zone type.
Type 81 AAV Monitor Zone	<ul style="list-style-type: none"> Assign to zone connected to AAV module. Monitors 2-way voice sessions as follows: <ul style="list-style-type: none"> When the zone is faulted, all alarm sounding and dialer reporting stops, except for fire alarms, which immediately terminate the voice session and cause a fire report to be sent. When the zone is restored (session ended), sounding resumes (if bell timeout has not expired) and reports that were stopped are sent.

Zone Type	Description
Type 82 Blockschloss	<ul style="list-style-type: none"> • Used with special Blockschloss lock and key. • System arms 5 seconds after the key is fully turned (arms MAXIMUM); key can then be removed. • When armed, the Blockschloss zone is shorted. An open circuit on this zone causes trouble condition. • If zones are “not ready,” the key will not turn fully and the system will not arm. • Contact ID report code is 409. • Once the system is armed using Blockschloss, it can be disarmed only by the key; wired keypads, RF keypads, and keyfobs cannot be used for disarming. • If any zone in the system is assigned as Blockschloss zone type, the system will not arm in AWAY mode. The system can, however, be armed in STAY or INSTANT modes from keypads and keyfobs even if the Blockschloss zone is faulted.
Types 90-93 Configurable	<ul style="list-style-type: none"> • Allows for various custom responses. • Options include response to entry/exit delays, response to opens/shorts, types of alarm/trouble sounding, dial delay, and unique Contact ID report codes. • Use *83 Menu mode to program these configurable zone types.

NOTE: All of the zone types described are available for the wireless portion of the system, if used.

Mechanics of Programming



To program the system from a keypad:

- You must use a 2-line Alpha display keypad.
- All partitions must be disarmed.

Data Field Programming Procedures

Task	Procedure
Entering Program Mode	a) Press both [*] and [#] at the same time within 50 seconds after power is applied to the control, OR b) After power-up, enter [Installer code (4-1-1-2)] + 8 0 0 (long beep indicates one of the partitions is armed and system cannot enter program mode). (method “B” is disabled if you exit the program mode using *98)
Go to a Data Field	Press [*] + [Field Number] (for example, *21). A display of “EE” or “Entry Error” means you have entered a nonexistent field. Simply re-enter [*] plus a valid field number.

Data Field Programming Procedures (cont'd)

Task	Procedure
Entering Data	When the desired field number appears, simply enter the digits required. The keypad beeps three times after the last digit is entered and automatically displays the next data field in sequence. If entering less than the maximum digits available (e.g., phone number field), enter the desired digits, then press [*] to end the entry.
Review a Data Field	Press [#] + [Field Number]. That field's data is displayed, but no changes can be made.
Deleting an Entry	Press [*] + [Field No.] + [*] (applies only to phone number, account number, and pager character fields).

Interactive Mode Programming (*56, *57, *58, *79, *80, *81, *82, *83)

Entering Interactive Mode	Press [*] + [Interactive Mode No.] (for example, *56) while in Program Mode. The Alpha display keypad will display the first of a series of prompts requesting entries. After making the appropriate entry, press the [*] key to accept the entry and continue to the next prompt.
---------------------------	--

Loading Factory Defaults/Initializing for Download

To Load Default Entries	Data Field, System, and Zone Defaults: The VISTA-12A and VISTA-12E each have two unique sets of default entries. The complete default tables are listed in the <i>Programming Guide</i> . Press *97 while in Program Mode, then press 1 or 2 to load the desired set of factory defaults (default set 1 or default set 2). This resets all data fields to the respective default set values shown in the <i>Programming Guide</i> . User Code Defaults: To reset only the user codes to default values, press *97, then press 3.
To Initialize Download ID	Press *96 while in Program Mode. This initializes the system for downloading and resets all the subscriber account numbers and CSID.



Do not press *97 to load defaults if any programming has been done previously—data already programmed into the system will be changed!

Exiting the Programming Mode

Prevent installer code reentry	Press *98. Exits Programming Mode and prevents re-entry by: Installer Code + [8] + [0] + [0]. To enter the programming mode if *98 was used to exit, you must first power the system down. Then power up again, and press [*] and [#] at the same time, within 50 seconds of powering up.
Allow installer code reentry	Press *99. Exits Programming Mode and allows re-entry by: Installer Code + [8] + [0] + [0] or by: Pressing [*] and [#] at the same time, within 50 seconds of power-up.

Table of Device Addresses

This Device	Uses Address	Reports as ^{††}	Enabled By...
RF Receiver	00	100	*56 zone programming: input device type entry
AUI 1	01	101	automatic if AUI enable field *189 enabled for AUI 1
AUI 2	02	102	automatic if AUI enable field *189 enabled for AUI 2
Alternative Communication Media (ACM) [†]	03	103	automatic if output to ACM field *29 enabled
Telecommand Voice Module	17-23	117-123	same as keypad enables; see below
Zone Expanders** (4219/4229): zones 17 - 24	08	108	*56 zone programming: input device type entry, then: automatic if zone no. 17-24 entered as AW type or relay assigned
Relay Module (4204/6164):	13	113	entered at device address prompt
Keypads: keypad 1 keypad 2 keypad 3 keypad 4 keypad 5 keypad 6 keypad 7 keypad 8	16 17 18 19 20 21 22 23	116 117 118 119 120 121 122 123	data field programming as listed below: always enabled for partition 1, all sounds enabled. data field *190 data field *191 data field *192 data field *193 data field *194 data field *195 data field *196
5800TM Module	28	n/a	automatic

[†] ACM devices include: 7845i Ethernet Interface Internet/Intranet, AI4164RS/AI4164ETH
RS485/Ethernet Eureka Network Interface

^{††} Addressable devices are identified by "1" plus the device address when reporting. Enter a report code for zone 91 to enable addressable device reporting (default = reports enabled). See field *199 for addressable device (ECP) 3-digit/2-digit identification keypad display options.

** or 6164 Keypad using zones; 08 = zones 17-20

Data Field Programming

About Data Field Programming

The following pages list this control's data fields in numerical order. Field numbers are listed in the left column followed by a "Title and Data Entries" column, which lists the valid entries for each field. Experienced installers can simply follow this column when programming the data fields. The "Explanation" column provides explanatory information and special notes where applicable.



Use the blank programming form to record the data for this installation.

Programming Data Fields

Data field programming involves making the appropriate entries for each of the data fields. Start Data Field programming by entering the installer code + 8 + 0 + 0.

System Setup Fields

FIELD	TITLE and DATA ENTRIES	EXPLANATION
*20	Installer Code Enter 4 digits, 0-9	The Installer Code is used to assign the 4-digit Master Security Code. See "Master Code" in the <i>System Operation</i> section for procedure.
*21	Quick Arm Enable 0 = do not allow quick arm 1 = allow quick arm	If enabled, a user code is not needed to arm the system. Instead, users can press the [#] followed by an arming key to arm the system. However, the user code is always needed to disarm the system.
*22	RF Options Entry 1 - Jam detection 0 = no RF Jam detection; 1 = detect RF Jam Entry 2 - supervision interval 0 = 12 hours; 1 = 2 hours; 2 = 20 minutes when disarmed/ 2 hours when armed 3 = 12 hrs for burg zones/ 3 hrs for fire zones	If jam detection enabled, a report is sent if the system detects an RF jamming signal. See field *178 for other jam/supervision options. When using RF Receivers with 5800 series transmitters, entry 2 should be 0 or 3.
*23	Quick (Forced) Bypass 0 = no quick bypass 1 = allow quick bypass (code + [6] + [#])	All zones bypassed by this function will be displayed after the bypass is initiated.
*24	RF House ID Code 00 = disable all wireless keypad usage 01-31 = House ID for partition 1, 2, 3	The House ID identifies receivers and wireless keypads. If a 5827 or 5827BD wireless keypad or 5804BD/5804BDV transmitter is being used, a House ID code must be entered, and the keypad must be set to the same House ID. You can assign RF house ID for each partition. Does not apply to 5839 or 5828/5828V.

FIELD	TITLE and DATA ENTRIES	EXPLANATION
*25	<p>Arming Prevention Override</p> <p>Entry 1: 0 = no arming prevention override 1 = allow system to arm with an RF supervision failure 2 = allow system to be armed with an AC Mains Loss 4 = allow system to be armed with a system low battery</p> <p>Entry 2: 0 = no tamper override 1† = allow system to be armed with a tamper fault 2† = allow system to be armed with a tamper fault once</p>	<p>If no override is selected, system will not be able to be armed when there is either a supervision failure, system low battery, AC mains loss, or a tamper condition.</p> <p>If override is enabled, the user must enter the arming sequence twice to arm the system; the first entry of user code + arm command will not arm, but a second entry of user code +arm command will arm the system.</p> <p>E.g., To select arm with “supervision failure” and “low battery”, enter 5 (1 + 4)</p> <p>† NOTE: If tamper option 1 or 2 is selected, field *175 digit 2 must be “0.”</p>
*26	<p>Chime By Zone List 3</p> <p>0 = no zone list (chimes on fault of any entry/exit or perimeter zone when chime mode on) 1 = use zone list (chimes on fault of specific zones programmed in zone list 3 when Chime mode on)</p>	<p>If enabled, you can define the specific zones intended to chime when faulted while the system is in Chime mode. Use zone list 3 to assign these zones (see *81 Zone List Programming section for details).</p>
*27	<p>Powerline Carrier Device (X-10) House ID</p> <p>0 = A 6 = G # + 11 = L 1 = B 7 = H # + 12 = M 2 = C 8 = I # + 13 = N 3 = D 9 = J # + 14 = O 4 = E # + 10 = K # + 15 = P 5 = F</p>	<p>Powerline Carrier devices require a House ID, identified in this field. Program Powerline Carrier devices in interactive modes *79, *80 and *81.</p>
*29	<p>ECP Contact ID Output for ACM</p> <p>0 = not used 1 = use Contact ID output on ECP</p>	<p>If selected, all messages programmed to go to the primary telephone line receiver will also be sent to the connected Alternative Communication Media (ACM), such as a 7845i Internet/Intranet Communicator or AI4164RS/AI4164ETH Eureka Network Interface (sent in Contact ID format). The data line is supervised as well as certain functions in a long range radio. If communication is lost or a trouble develops, an attempt will be made to send a message via both ACM and telephone to the central station.</p> <p>Program the ACM for device address 3.</p>

Zone Sounds & Timing

FIELD	TITLE and DATA ENTRIES	EXPLANATION
*31	Single Alarm Sounding Per Zone (per armed period) 0 = no limit on alarm sounding per zone 1 = limit alarm sounding to once per arming period for a given zone	Select whether a zone going into alarm should sound more than once per armed period.
*32	Fire Alarm Sounder Timeout 0 = yes; fire sounder timeout after time programmed in field *33 1 = no fire sounder timeout; continue sounding until manually turned off	Select whether fire alarm sounding expires after sounder timeout or remains until manually turned off.
*33	Siren Timeout 0 = No timeout 4 = 4 min 1 = 1 min 5 = 8 min 2 = 2 min 6 = 16 min 3 = 3 min	This field determines whether the external sounder will shut off after time allotted, or continue until manually turned off.
*34	Exit Delay 00 - 96 = 0 - 96 seconds 97 = 120 seconds	The system waits the time entered before arming entry/exit zones. If the entry/exit door is left open after this time expires, an alarm will occur or the zone will be auto-bypassed, depending on the selection in field *88. Common area zones use same delay as partition 1.
*35	Entry Delay 1 00 - 96 = 0 - 96 seconds 97 = 120 seconds 98 = 180 seconds 99 = 240 seconds	Upon entering, the system must be disarmed before the time entered expires, otherwise it sounds an alarm. Common area zones use same delay as partition 1.
*36	Entry Delay 2 See *35 above for entries.	See *35 for explanation.
*37	Audible Exit Warning 0 = no; 1 = yes	Warning sound consists of slow continuous beeps until last 10 seconds, then it changes to fast beeps. Sound ends when exit time expires.

FIELD	TITLE and DATA ENTRIES	EXPLANATION
-------	------------------------	-------------

***38** **Confirmation Of Arming Ding**
Entry 1: 0 = no; 1 = yes, 1-second ding (ding if armed from wired keypad)
Entry 2: Enter 0-15 from table below. (ding if armed from RF device)

Entry	Ding at Siren	Trigger 2 Output
0	none	none
1	none	250mS
2	none	1 second
3	none	4 seconds
4	250mS	none
5	250mS	250mS
6	250mS	1 second
7	250mS	4 seconds
8	1 second	none
9	1 second	250mS
#+10	1 second	1 second
#+11	1 second	4 seconds
#+12	4 seconds	none
#+13	4 seconds	250mS
#+14	4 seconds	1 second
#+15	4 seconds	4 seconds

Entry 1 for each partition selects whether arming from wired keypads causes siren ding. Confirmation of arming is an external sounder “ding” that follows the time selected in entry 2 for “ding at siren.” Ding occurs when closing reports is sent, or when exit delay expires.

Entry 2 for each partition selects whether arming from remote RF devices causes siren ding and/or activates trigger 2 output; also selects siren ding/trigger activation duration (arm = 2 dings of selected duration with 1 second off between; disarm = 1 ding of selected duration). Ding occurs upon reception of the wireless arming command.

NOTE: If using an option that activates trigger 2, trigger 2 must be dedicated to only this function; do not assign any other functions to trigger 2.

***39** **Power-Up In Previous State**
 0 = always power-up in a disarmed state
 1 = assume the system status prior to power down

When the system powers up armed, an alarm will occur 1 minute after arming if a zone is faulted at that time.
 Note that if the previous state was armed AWAY or STAY, the system will not respond to sensor changes for 1 minute, which allows time for sensors such as PIRs to stabilize.

Dialer Programming (*40 – *55)

FIELD	TITLE and DATA ENTRIES	EXPLANATION
-------	------------------------	-------------

***40** **PABX Access Code**
 Enter up to 6 digits if PABX is needed to access an outside line. Do not fill unused spaces.
 0–9, # + 11 for ‘*’, # + 12 for ‘#’, # + 13 for a pause (2 seconds)

To clear entries from field, press *40*. If fewer than 6 digits need to be entered, exit by pressing [*], which advances to the next field.

Call Waiting: If the subscriber’s phone service has “call waiting” (and is not using PABX), enter “*70” (“# + 11”) plus “# + 13” (pause) as the PABX entry to disable “call waiting” during control panel calls. If the subscriber does not have “call waiting” and is not using PABX, make no entry in this field.

***41** **Primary Phone No.**
 Enter up to 30 digits. Do not fill unused spaces.
 0–9, # + 11 for ‘*’, # + 12 for ‘#’, # + 13 for a pause (2 seconds)

If you enter fewer than 30 digits, exit by pressing [*]. To clear entries from field, press *41*.
NOTE: Backup reporting (in which 8 calls are made to the secondary phone number if no kissoff is received after 8 attempts to the primary number) is automatic only if there is a secondary phone number (field *42).

FIELD	TITLE and DATA ENTRIES	EXPLANATION																		
42	Secondary Phone No. Enter up to 30 digits. 0-9, # + 11 for '', # + 12 for '#', # + 13 for a pause (2 seconds)	If you enter fewer than 30 digits, exit by pressing [*]. To clear entries from field, press *42*. See backup reporting note for field *41. Don't fill unused spaces.																		
*43	Part. 1 Primary Subs. Acct. No. Enter digits 0-9; # + 11 for B, # + 12 for C, # + 13 for D, # + 14 for E, # + 15 for F.	Enter up to 10 digits, depending on the report format selected in field *48. To clear entries from field, press *43*.																		
*44	Part. 1 Secondary Subs. Acct. No. Enter digits 0-9; # + 11 for B, # + 12 for C, # + 13 for D, # + 14 for E, # + 15 for F.	Enter up to 10 digits, depending on the report format selected in field *48. To clear entries from field, press *44*.																		
*45	Part. 2 Primary Subs. Acct. No. Enter digits 0-9; # + 11 for B, # + 12 for C, # + 13 for D, # + 14 for E, # + 15 for F.	Enter up to 10 digits, depending on the report format selected in field *48. To clear entries from field, press *45*.																		
*46	Part. 2 Secondary Subs. Acct. No. Enter digits 0-9; # + 11 for B, # + 12 for C, # + 13 for D, # + 14 for E, # + 15 for F.	Enter up to 10 digits, depending on the report format selected in field *48. To clear entries from field, press *46*.																		
*47	Phone System Select/Dialer Attempts Phone System Select: If Central Station Receiver is not on satellite link: 0 = Decadic Pulse Dial; 1 = Multifrequency Tone Dial If Central Station Receiver is on satellite link: 2 = Decadic Pulse Dial; 3 = Multifrequency Tone Dial Dialer Attempts: 1 - 10 (for 10, enter #+10)	Phone System Select: Select the type of telephone service. Dialer Attempts: Enter the number of times the system should attempt to dial the central station, 1 - 10 times (for 10, enter #+10).																		
48	Report Format (Primary/Secondary) 0 = 3+1, 4+1 ADEMCO L/S STANDARD 1 = 3+1, 4+1 RADIONICS STANDARD 2 = 4+2 ADEMCO L/S STANDARD 3 = 4+2 RADIONICS STANDARD 5 = CID using 10-digit account number 6 = 4+2 ADEMCO EXPRESS 7 = CID* using 4-digit account number 8 = 3+1, 4+1 ADEMCO L/S EXPANDED 9 = 3+1, 4+1 RADIONICS EXPANDED 10 = ROBOFON 8 (6-digit account number) 11 = ROBOFON Contact ID	Select report format for primary and secondary phone numbers. * ADEMCO Contact ID format Audio Beeps Format (Follow-Me): To enable the audio "beeps" format (Follow-Me feature), refer to the System Features section later in this manual, and the User Guide. Special Contact ID Report Codes: The following three reports are valid only when Contact ID format is enabled: 412-Successful Download/Access (see field *53), 461-Wrong Code Entry (see field *188), and 626-Time/Date Inaccurate (see field *53).																		
*49	Split/Dual Reporting 0 = disable (standard/backup report only). 1 - 5 (see table to right)	<table border="1"> <thead> <tr> <th>To Primary No.</th> <th>To Secondary No.</th> <th>To</th> </tr> </thead> <tbody> <tr> <td>1 =</td> <td>alarms, restore, cancel</td> <td>others</td> </tr> <tr> <td>2 =</td> <td>all except open/close, test</td> <td>open/close,</td> </tr> <tr> <td>3 =</td> <td>alarms, restore, cancel</td> <td>all</td> </tr> <tr> <td>4 =</td> <td>all except open/close, test</td> <td>all</td> </tr> <tr> <td>5 =</td> <td>all</td> <td>all</td> </tr> </tbody> </table>	To Primary No.	To Secondary No.	To	1 =	alarms, restore, cancel	others	2 =	all except open/close, test	open/close,	3 =	alarms, restore, cancel	all	4 =	all except open/close, test	all	5 =	all	all
To Primary No.	To Secondary No.	To																		
1 =	alarms, restore, cancel	others																		
2 =	all except open/close, test	open/close,																		
3 =	alarms, restore, cancel	all																		
4 =	all except open/close, test	all																		
5 =	all	all																		

FIELD	TITLE and DATA ENTRIES	EXPLANATION
*50	Burglary Dialer Delay 0 = no dial delay 1 = 15 seconds 2 = 30 seconds 3 = 45 seconds	Provides delay of "BURGLARY ALARM" report to the central station, which allows time for the subscriber to avoid a false alarm transmission. This delay does not apply to zone type 24 alarms (silent burglary) or to 24-hour zone types 6, 7, and 8 (silent panic, audible alarm, auxiliary alarm), which are always sent as soon as they occur.
*51	Common Partition Primary Subs. Acct. No. Enter digits 0-9; # + 11 for B, # + 12 for C, # + 13 for D, # + 14 for E, # + 15 for F.	Enter up to 10 digits, depending on the report format selected in field *48.
*52	Common Partition Secondary Subs. Acct. No. Enter digits 0-9; # + 11 for B, # + 12 for C, # + 13 for D, # + 14 for E, # + 15 for F.	Enter up to 10 digits, depending on the report format selected in field *48.
*53	SESCOA/Radionics Select/ CID Codes SESCOA/Radionics: 0 = Radionics (0-9, B-F reporting) 1 = SESCOA (0-9 only reporting) Contact ID Codes: 0 = disable both Time/Date Inaccurate and Successful Download/Access reports 1 = enable Time/Date Inaccurate report (code 626); 2 = enable Successful Download/Access report (code 412) 3 = enable both Time/Date Inaccurate and Successful Download/Access	SESCOA/Radionics: Select SESCOA or Radionics format. Select 0 for all other formats. Contact ID (CID) Codes: If desired, enable the Time/Date Inaccurate and/or Successful Download/Access report codes. These reports are valid only when Contact ID reporting format is used.
*54	Dynamic Signaling Delay 0 = disabled (both signals sent) 1-15 = entry times a 15-second delay. e.g., 1 = 15 seconds, 2 = 30 seconds, etc.	Intended for use with ECP Contact ID Output reporting via ACM. This field lets you select the time the panel should wait for acknowledgment from the first reporting destination (see *55) before it attempts to send a message to the second destination. Delays can be selected from 0 to 225 seconds, in 15-second increments. This delay is per message. If "0" is entered in this field, the control panel will send redundant reports to both Primary Dialer and ECP output.

FIELD	TITLE and DATA ENTRIES	EXPLANATION
*55	Dynamic Signaling Priority 0 = Primary dialer first; 1 = ECP Contact ID output first.	<p>Intended for use with Alternative Communication Media reporting.</p> <p>You must also enable field *29, ECP Contact ID Output for ACM.</p> <p>Select the initial reporting destination for messages as follows:</p> <p>Primary Dialer First selected (0):</p> <ul style="list-style-type: none"> • If acknowledged before delay expires (see *54), then message will not be sent to ECP output. • If not acknowledged before delay expires, then message is sent to both the Primary Phone No. and ECP output. <p>ECP Contact ID Output First selected (1):</p> <ul style="list-style-type: none"> • If acknowledged before delay expires, then message will not be sent to the primary dialer. • If not acknowledged before delay expires, then message is sent to both the Primary Phone No. and ECP Contact ID output.

System Status Report Codes

Zone report codes are programmed using interactive *56 or *58 Zone Programming modes, while system status (non-alarm) codes and restore codes are entered in the following data fields. The actual report code digits that you enter depend upon the particular installation, and should agree with the Central Station office receiving the signals.

To disable a report code, enter "0" in the first entry.

3+1, 4+1 Standard or Robofon 8 Format: Enter a code in the first entry: 1–9, A, B, C, D, E, or F. Enter #+10 for A (this reports a "0" on some receivers), #+11 for B, #+12 for C, #+13 for D, #+14 for E, #+15 for F.

Entering 0 in the second box advances to the next field.

Expanded or 4+2 Format: Enter codes in both entries (first and second digits) for 1–9 or A–F, as described above. An entry of "0" in the second entry eliminates the expanded message for that report.

ADEMCO or Robofon Contact ID® Reporting: Enter a digit in the first entry to enable the zone to report. Use a different digit for each zone until you have used up available digits. If the number of zones exceeds the number of available digits, begin with digit 1 again. This is an "enabling" code only and is not the actual code sent to the Central Station office. Entries in the second entry pair are ignored. An entry of 0 in the first box disables the report.

FIELD	TITLE and DATA ENTRIES	EXPLANATION
*59	Exit Error Report Code 0 = no report 1-F = report code; see description above	<p>After arming the system, zones remaining open after exit delay expires cause an alarm sound at the keypad and external sounder (keypad also displays "EXIT ALARM"), and entry delay begins. Disarming before the end of the entry delay stops the alarm sounding and no message is sent to the central station. The keypad will display "CA" (fixed-word) or "CANCELED ALARM" (alpha display).</p> <p>If the system is not disarmed before entry delay expires, an "EXIT ALARM" message will be sent to the central station if Exit Error Report Code is enabled. The keypad will display "EA" (fixed-word) or "EXIT ALARM" (alpha display), and alarm sounding continues until the system is disarmed (or timeout occurs).</p> <p>An Exit Alarm condition will also result if a fault occurs in an exit or interior zone within 2 minutes following the end of the exit delay, and an "EXIT ALARM" message will be sent to the central station.</p> <p>With Contact ID format, the message will contain the zone number and error code 374 ("ALARM-EXIT ERROR").</p>
*60	Trouble Report Code 0 = disable; 1-F = see description above *59	Sent if a zone has a trouble condition.
*61	Bypass Report Code 0 = disable; 1-F = see description above *59	Sent when a zone is manually bypassed or is automatically bypassed at the end of exit delay.
*62	AC Mains Loss Report Code 0 = disable; 1-F = see description above *59	Timing of this report is random with up to a 1-hour delay. If AC mains restores before the report goes out, there is no "AC RESTORE" report.
*63	Low Battery Report Code 0 = disable; 1-F = see description above *59	Sent when a low-battery condition exists in the system's battery.
*64	Test Report Code 0 = disable; 1-F = see description above *59	Sent periodically to test that the communicator and phone lines are operational. Frequency of report is set in Scheduling mode (event 11).
*65	Open Report Code 0 = disable; 1-F = see description above *59	Sent upon disarming of the system in the selected partitions.
*66	Arm Away/Stay Report Code 1-F = see description above *59	<p>This option allows for independent programming of Away and Stay reports for each partition.</p> <p>NOTE: "OPEN" reports are not sent if the associated closing report is not enabled.</p>
*67	RF Low Battery Report Code 0 = disable; 1-F = see description above *59	Sent when a wireless transmitter low-battery condition exists.
*68	Cancel Report Code 0 = disable; 1-F = see description above *59	Sent upon disarming of the system after an alarm condition was reported.

FIELD	TITLE and DATA ENTRIES	EXPLANATION
*69	Alarm Restores Send restore code (if fault cleared): 0 = at siren timeout (if restored) or at disarm (whether restored or not) 1 = dynamically as the fault clears 2 = only after a disarm	Alarm restore message will be sent upon condition selected.
*70	Alarm Restore Report Code 0 = disable; 1-F = see description above *59	Sent when an alarm zone is restored to its non-faulted condition or at the times selected in field *69.
*71	Trouble Restore Report Code 0 = disable; 1-F = see description above *59	Sent when a trouble in a zone is restored
*72	Bypass Restore Report Code 0 = disable; 1-F = see description above *59	Sent when a zone that has been bypassed is unbypassed, either manually or when the partition/system is disarmed.
*73	AC Mains Restore Report Code 0 = disable; 1-F = see description above *59	Sent when AC mains has been restored after an AC mains outage.
*74	Low Battery Restore Report Code 0 = disable; 1-F = see description above *59	Sent when a system low-battery condition is restored to normal.
*75	RF Low Battery Restore Code 0 = disable; 1-F = see description above *59	Sent when a transmitter's low battery condition is restored (i.e., new battery installed).
*76	Test Restore Report Code 0 = disable; 1-F = see description above *59	Sent when the Test mode is exited.

Miscellaneous System Fields

FIELD	TITLE and DATA ENTRIES	EXPLANATION
*77	Summer Time Start/End Month 0 = Disabled 4 = April 1 = Jan # + 10 = Oct 2 = Feb # + 11 = Nov 3 = Mar # + 12 = Dec	Enter the start and end month for summer time, if applicable to the region.
*78	Summer Time Start/End Weekend 0 = disabled 4 = fourth 1 = first 5 = last 2 = second 6 = next to last 3 = third 7 = third to last	Enter the start and end weekend for summer time, if applicable to the region.

FIELD	TITLE and DATA ENTRIES	EXPLANATION																		
*84	<p>Auto-Stay Arm 0 = no 1 = partition 1 only 2 = partition 2 only 4 = partition 3 only Add values for multiple partitions (e.g., for partitions 1 and 2, enter 3).</p>	<p>If enabled, the system will automatically change AWAY or MAXIMUM modes to STAY and INSTANT modes respectively if the entry/exit door is not opened and closed within the exit delay time after a user arms in AWAY mode from a wired keypad (non-RF device). An Opening report followed by an Armed Stay report is sent to the Central Station.</p> <p>If the door is opened and closed within the exit delay period, the system remains in AWAY or MAXIMUM mode.</p> <p>Any RF device that arms the system AWAY overrides this feature and the system remains armed in the AWAY mode.</p> <p>NOTE: Must not be used if TeleCommand is used. Does not apply if:</p> <ul style="list-style-type: none"> • Final Contact Set exit option (field *88, option 3) is enabled. • Blockschloss is being used. 																		
*85	<p>Linked Zone Verification Timer Up and About</p> <p>Linked Zone Timer Entry:</p> <table> <tr> <td>0 = 15 secs</td> <td>6 = 2-1/2 min</td> <td>#+12 = 8 min</td> </tr> <tr> <td>1 = 30 secs</td> <td>7 = 3 min</td> <td>#+13 = 10 min</td> </tr> <tr> <td>2 = 45 secs</td> <td>8 = 4 min</td> <td>#+14 = 12 min</td> </tr> <tr> <td>3 = 60 secs</td> <td>9 = 5 min</td> <td>#+15 = 15 min</td> </tr> <tr> <td>4 = 90 secs</td> <td>#+10 = 6 min</td> <td></td> </tr> <tr> <td>5 = 2 min</td> <td>#+11 = 7 min</td> <td></td> </tr> </table> <p>Up and About Timer Entry: 1 through 15 for number of hours</p>	0 = 15 secs	6 = 2-1/2 min	#+12 = 8 min	1 = 30 secs	7 = 3 min	#+13 = 10 min	2 = 45 secs	8 = 4 min	#+14 = 12 min	3 = 60 secs	9 = 5 min	#+15 = 15 min	4 = 90 secs	#+10 = 6 min		5 = 2 min	#+11 = 7 min		<p>Linked Zone Timer: Sets the maximum amount of time in which two linked zones must be tripped in an armed system to send an alarm message to the Central Station. If only one linked zone is tripped during this time, a trouble message (CID code 380) for that zone is sent to the Central Station. Assign linked zone pairs in zone list 4.</p> <p>Up and About Timer: 1-15 hours. This option is part of an Up and About schedule (event 12) that must be programmed. The value in this field is the time within which activity must occur within the overall scheduled up and about time window. If no zones are faulted or no key is pressed within the selected time period during the scheduled Up and About time window, a report is sent to the central station. This can serve as a safety feature for elderly, infirm, or disabled persons. See <i>Programming Installer and User Schedules</i> section for programming schedules.</p>
0 = 15 secs	6 = 2-1/2 min	#+12 = 8 min																		
1 = 30 secs	7 = 3 min	#+13 = 10 min																		
2 = 45 secs	8 = 4 min	#+14 = 12 min																		
3 = 60 secs	9 = 5 min	#+15 = 15 min																		
4 = 90 secs	#+10 = 6 min																			
5 = 2 min	#+11 = 7 min																			
*86	<p>Cancel Verify Keypad Display 0 = no "Alarm Canceled" display 1 = yes, display "Alarm Canceled"</p>	<p>When enabled (1 = yes), this feature causes an "ALARM CANCELED" display at the keypad whenever the system is disarmed after an alarm has occurred.</p> <p>NOTE: To clear the "ALARM CANCELED" display, the user must enter the security code + OFF.</p>																		

FIELD	TITLE and DATA ENTRIES	EXPLANATION
*87	Misc. Fault Delay Time 0 = 15 secs 6 = 2-1/2 min #+12 = 8 min 1 = 30 secs 7 = 3 min #+13 = 10 min 2 = 45 secs 8 = 4 min #+14 = 12 min 3 = 60 secs 9 = 5 min #+15 = 15 min 4 = 90 secs #+10 = 6 min 5 = 2 min #+11 = 7 min	Used with zones assigned to a configurable zone type with fault delay on (selected in alarm/trouble processing prompt), and sets a zone response time of 15 seconds to 15 min. It can be assigned to zones with sensors that provide a trouble indication when an oil or gas tank is low, or similar applications for critical condition monitoring where a non-alarm response is desired and where the zone response time should be very long to avoid reacting to normal transient faults.
*88	Exit Options 0 = all intrusion zones must be intact before arming 1 = All intrusion zones except in exit path (zone list 12) must be intact before arming. Will go into alarm if not restored at end of exit time 2 = All intrusion zones except in exit path (zone list 12) must be intact before arming. Will be bypassed if not restored at end of exit time 3 = Final contact set: All intrusion zones except in exit path (zone list 12) must be intact before arming. Once armed, exit delay remains on indefinitely until the last zone, as defined in zone list 8, is restored; then there is 5-second exit delay before arming state is active	Select the desired option. NOTE: Must be "0" if system uses zone type 82 - Blockschloss.
*89	Event Log Full Report Code 0 = disable; 1-F = see description above *59	If an Event Logging selection is made in field *90, a message can be sent to the central station receiver when the log is 80% full. If the log becomes full, new messages overwrite the oldest messages in the log.
*90	Event Log Enables 0 = no event logging 1 = log Alarm/Alarm Restore 2 = log Trouble/Trouble Restore 4 = log Bypass/Bypass Restore 8 = log Open/Close x = log combination of events (add value of entries)	This system has the ability to record up to 254 events in a history log. At any time, the downloader operator can then upload the log and view or print out all or selected categories of the log. The downloader operator can also clear the log. Event log can also be viewed at an alpha keypad (see User Guide for log display format). The display/printout at the central station will show the date, time, event, and description of the occurrences. Data Entry Example: To select Alarm/Alarm Restore" and "Open/Close", enter 9 (1+ 8); to select all events, enter #15.

FIELD	TITLE and DATA ENTRIES	EXPLANATION
91	<p>Miscellaneous Options</p> <p>Entry 1 – AAV and Exit Delay Restart: 0 = none 4 = using Audio Alarm Verification (AAV) unit 8 = Enable Exit delay restart/reset ††</p> <p>Multiple choice example: for both AAV and Exit delay restart, enter # + 12 (4 + 8).</p> <p>Entry 2 – Output Activation Commands: 0 = allow keypad output activation commands (user code + # + 7 and user code + # + 8) 1 = do not allow keypad output activation commands</p>	<p>Entry 1: Select the desired options by adding the values of each desired option.</p> <p>††“Exit Delay Restart/reset” option allows use of the [] key to restart the exit delay at any time when the system is armed STAY or INSTANT. This feature also enables automatic exit delay reset, which resets exit delay if the entry/exit door is re-opened and closed before exit delay time expires after arming AWAY or MAXIMUM.</p> <p>Entry 2: Select whether to allow outputs to be activated by the keypad activation commands (user code + # + 7 and user code + # + 8).</p> <p>IMPORTANT: AAV should not be used when Paging or Alarm Reports are sent to a secondary number unless the monitoring zone option is used (which pauses calls). Otherwise, the call to the secondary number by the communicator after the alarm report will prevent the AAV from taking control of the telephone line, and the AAV “Listen in” session cannot take place.</p>
*92	<p>Telecom Monitor Enable</p> <p>Entry 1–Timeout: 0 = disabled 1-15 = 1 minute to 15 minutes respectively (2 = 2 min, 3 = 3 min, etc.; # + 10 = 10 min, # + 11 = 11 min, # + 12 = 12 min, # + 13 = 13 min, # + 14 = 14 min, # + 15 = 15 min)</p> <p>Entry 2–Display/Sound: 0 = keypad display only when phone line is faulted. 1 = keypad display plus keypad trouble sound when line is faulted. Each partition turns off its own trouble sound. No automatic timeout. 2 = Same as “1” plus programmed output device STARTS. If any partition is armed, external sounder activates. External sounder will be turned off by normal siren timeout or by security code plus OFF from any partition (it does not have to be the one that was armed).</p>	<p>Entry 1: Sets the length of time a phone line fault must remain after detected before the second digit option is activated.</p> <p>Entry 2: Selects the desired phone line fault response. Option 2 may be used even if a relay unit or Powerline carrier device is not connected to the control. Programmed Output Device must either be programmed to be STOPPED in field *80 or STOPPED by entry of [security code] + [#] + 8 + device number. Partition in *80 should be set to “0,” for STOP.</p>
*93	<p>No. of Reports In Armed Period per Zone (Intermittent Sensor Suppression) 0 = unlimited number of reports 1 – 6 = 1 – 6 report pairs per zone per armed period</p>	<p>This option can be used to limit the number of alarm/alarm restore messages per zone sent to the central station in an armed period.</p>

FIELD	TITLE and DATA ENTRIES	EXPLANATION																																				
94	Download Phone Number Enter up to 30 digits as follows: 0-9, # +11 for "", # + 12 for "#", # + 13 for a pause.	Enter the phone number of the downloading computer. Do not fill unused spaces. End field by entering *. To clear entries from field, press *94*.																																				
*95	Ring Count For Downloading 0 = Disable Monitoring Station initiated downloading 1-14 = number of rings before control answers incoming call #+15 = Answering machine/fax defeat	Refer to the chart below and program this field accordingly. <table border="1"> <thead> <tr> <th>phone module</th> <th>answer/fax machine</th> <th>down-loading</th> <th>Set field *95 to...</th> </tr> </thead> <tbody> <tr> <td>yes</td> <td>no</td> <td>no</td> <td>1-14 (not 0)</td> </tr> <tr> <td>yes</td> <td>yes</td> <td>no</td> <td>higher than number of rings set on answer/fax machine (e.g., if ans/fax machine is 4 rings, set this field to 5). This allows access via the phone module if the answer/fax machine is turned off.</td> </tr> <tr> <td>yes</td> <td>no</td> <td>yes</td> <td>1-14 (not 0)</td> </tr> <tr> <td>yes</td> <td>yes</td> <td>yes</td> <td>15 (bypasses answer/fax machine[†])</td> </tr> <tr> <td>no</td> <td>no</td> <td>no</td> <td>0</td> </tr> <tr> <td>no</td> <td>yes</td> <td>no</td> <td>0</td> </tr> <tr> <td>no</td> <td>no</td> <td>yes</td> <td>1-14</td> </tr> <tr> <td>no</td> <td>yes</td> <td>yes</td> <td>15</td> </tr> </tbody> </table> <p>[†] NOTE: If "15" is entered to bypass an answering machine and a TeleCommand Phone Module is included in the system, you should note the following: When calling in from an off-premises phone, the user should make the initial call, allow 1 or 2 rings only, then hang up, then call again. The phone module will now seize the line, and 2 long tones sound, followed by the usual voice prompt for the access code. If this procedure is not followed, phone module operation will not be possible.</p>	phone module	answer/fax machine	down-loading	Set field *95 to...	yes	no	no	1-14 (not 0)	yes	yes	no	higher than number of rings set on answer/fax machine (e.g., if ans/fax machine is 4 rings, set this field to 5). This allows access via the phone module if the answer/fax machine is turned off.	yes	no	yes	1-14 (not 0)	yes	yes	yes	15 (bypasses answer/fax machine [†])	no	no	no	0	no	yes	no	0	no	no	yes	1-14	no	yes	yes	15
phone module	answer/fax machine	down-loading	Set field *95 to...																																			
yes	no	no	1-14 (not 0)																																			
yes	yes	no	higher than number of rings set on answer/fax machine (e.g., if ans/fax machine is 4 rings, set this field to 5). This allows access via the phone module if the answer/fax machine is turned off.																																			
yes	no	yes	1-14 (not 0)																																			
yes	yes	yes	15 (bypasses answer/fax machine [†])																																			
no	no	no	0																																			
no	yes	no	0																																			
no	no	yes	1-14																																			
no	yes	yes	15																																			

Pager Programming Fields

FIELD	TITLE and DATA ENTRIES	EXPLANATION
160	Pager 1 Phone No. Enter up to 20 digits	If you enter fewer than 20 digits, exit by pressing [] and next field number. To clear entries from this field, press *160*.

FIELD	TITLE and DATA ENTRIES	EXPLANATION
*164	Pager 2 Characters Enter up to 16 characters	See field *161 for explanation. If fewer than 16 characters, exit by pressing [*] and next field number. To clear entries, press *164*.
*165	Pager 2 Report Options see pager 1 reports, field *162 for entries, except use zone list 10.	Enter the types of reports to be sent to pager 2 for each partition.
*166	Pager Delay Option for Alarms 0 = none 2 = 2 minutes 1 = 1 minute 3 = 3 minutes	This field determines the delay of alarm reports to the pager. This gives the Central Station enough time to verify the alarm report that it received, before the dialer attempts to dial the pager. NOTE: The delay does not reset for new alarms occurring while an existing pager delay is in progress. This delay is for ALL pagers in the system.

Miscellaneous System Fields

FIELD	TITLE and DATA ENTRIES	EXPLANATION
*173	RF REPORTING OPTIONS 0 = none 1 = RF Tamper reports during disarm 2 = RF keyfobs send low battery 3 = RF Tamper reports during disarm and RF keyfobs send low battery	Select desired option.
*175	Tamper Options Entry 1: 0 = standard tamper detection 1 = detect tamper from bypassed zones 2 = detect tamper when in Test mode 3 = detect tamper both when in Test mode and from bypassed zones Entry 2: 0 = all users can clear a tamper** 1 = only the installer can clear a tamper	Select desired options. Standard Tamper Detection (entry 1 option 0): The system normally detects tamper faults from devices equipped with tamper switches (for cover removal and/or wall removal) while the system is armed or disarmed. Tamper faults are ignored when a zone is bypassed or when the system is in Test mode unless entry 1 options 1, 2, or 3 are selected. Tamper display is as follows: Disarmed: TAMPER 1xx (or zz) where 1xx = ECP device address zz = zone number of faulted device. Armed: TMPR_ARMD ** Must be "0" if field *25 entry 2 is set for 1 or 2, otherwise, only the installer will be able to disarm the system and clear tamper displays.

FIELD	TITLE and DATA ENTRIES	EXPLANATION
*176	<p>Siren Options</p> <p>Entry 1: 0 = external siren 1 = self-activated external siren</p> <p>Entry 2: 0 = disable siren delay 1 = external siren delay and dialer delay during entry delay period when armed AWAY 2 = external siren and dialer delayed 15 seconds when armed STAY mode</p>	<p>Select desired options.</p> <p>Entry 1: If entry 1 is not set to an external siren (option 0 or 1), then the second entry is ignored.</p> <p>Entry 2: Option 1 – When entry delay is active (ex. reentering premises while armed AWAY) and an instant zone is faulted, the external siren is delayed 30 seconds and the dialer report is delayed 30 seconds, unless field *50 is set for a greater delay (the 30-second dialer delay supersedes values less than 30 seconds set in field *50).</p> <p>Option 2 – When armed STAY and an instant zone is faulted, the external siren and dialer are delayed 15 seconds (keypad sounds immediately).</p>
*177	<p>Device Duration 1, 2</p> <p>Duration 1 – Device Action 5 Timer</p> <p>0 = 15 secs 6 = 2-1/2 min #+12 = 8 min 1 = 30 secs 7 = 3 min #+13 = 10 min 2 = 45 secs 8 = 4 min #+14 = 12 min 3 = 60 secs 9 = 5 min #+15 = 15 min 4 = 90 secs #+10 = 6 min 5 = 2 min #+11 = 7 min</p> <p>Duration 2 – Device Action 6 Timer</p> <p>1 – 7 = 1 to 7 days</p>	<p>These entries set the duration for output action options 5 (duration 1) and 6 (duration 2) programmed in *80 Output Function Programming. Duration 2 can be used as a strobe timer.</p>
*178	<p>RF Supervision / RF Jam Option</p> <p>0 = RF supervision and RF jam detection reporting</p> <p>1 = Report RF supervision failure as tamper alarm when armed</p> <p>2 = Report RF Jam as tamper alarm when armed</p> <p>3 = Report RF Jam and RF supervision failure as tamper alarm when armed</p> <div style="border: 1px solid black; padding: 5px; margin-top: 10px;"> <p>NOTES: RF Jam must be enabled in field *22 in order for any RF reporting to be enabled in this field. Alarm restore reports must be enabled (field *70) in order for RF Supervision/RF Jam alarm restores to be reported. Trouble reports and trouble restore reports must be enabled (fields *60, *71) in order for RF supervision/RF jam trouble conditions and restores to be reported.</p> </div>	<p>Select desired option. See field *22 for related options.</p> <p>Entry 0: RF jam conditions report as Trouble zone 90 (Contact ID code 344, RF Rcvr Jam Detect) plus a zone trouble report for each RF zone in the system (CID code 383, Trouble Sensor Tamper) when the system is armed or disarmed. Keypads display Tamper zz (zz = zones) and Tamper 90 (fixed-word) or RECEIVER JAM (alpha).</p> <p>RF supervision failures report as zone troubles (CID code 381, RF Sensor Super.) when the system is armed or disarmed. Keypads display CHECK zz (zz = zone).</p> <p>Entry 1: Same as entry 0 except RF supervision failures report as zone alarms (CID code 144, Alarm Sensor Tamper) when the system is armed; keypads display ALARM zz.</p> <p>Entry 2: Same as entry 0 except RF jam conditions report as zone alarms (Contact ID code 144, Alarm Sensor Tamper) when the system is armed; keypads display ALARM zz.</p> <p>Entry 3: Same as entry 0 when disarmed, but when system armed, both RF jam conditions and RF supervision failures report as zones alarms (Contact ID code 144, Alarm Sensor</p>

		Tamper)																																																																																					
FIELD	TITLE and DATA ENTRIES	EXPLANATION																																																																																					
*180	Zone Bypass Limit 0 = unlimited zone bypasses in each partition 1-7 = number of zone bypasses allowed in each partition 8 = zone bypass disabled (no zones can be bypassed)	Select the maximum number of zones that can be bypassed. Each partition individually uses this entry.																																																																																					
*181	AC and Clock Display Options 0-15 = desired options based on chart at right.	Use the following table to select the desired options for real-time clock synchronization (50Hz, 60Hz, Crystal), AC loss display (independent of AC loss report enabled in *62), and clock display (time displayed on bottom line of alpha keypads). X10 NOTE: "X10" (powerline carrier devices) use the selected AC frequency to communicate with the control.																																																																																					
		<table border="1"> <thead> <tr> <th>Entry</th> <th>AC Freq.</th> <th>Crystal for</th> <th>AC Loss disp</th> <th>Clock disp</th> </tr> </thead> <tbody> <tr><td>0</td><td>60Hz</td><td>clock backup</td><td>no</td><td>no</td></tr> <tr><td>1</td><td>50Hz</td><td>clock backup</td><td>no</td><td>no</td></tr> <tr><td>2</td><td>60Hz</td><td>clock</td><td>no</td><td>no</td></tr> <tr><td>3</td><td>50Hz</td><td>clock</td><td>no</td><td>no</td></tr> <tr><td>4</td><td>60Hz</td><td>clock backup</td><td>yes</td><td>no</td></tr> <tr><td>5</td><td>50Hz</td><td>clock backup</td><td>yes</td><td>no</td></tr> <tr><td>6</td><td>60Hz</td><td>clock</td><td>yes</td><td>no</td></tr> <tr><td>7</td><td>50Hz</td><td>clock</td><td>yes</td><td>no</td></tr> <tr><td>8</td><td>60Hz</td><td>clock backup</td><td>no</td><td>yes</td></tr> <tr><td>9</td><td>50Hz</td><td>clock backup</td><td>no</td><td>yes</td></tr> <tr><td>#+10</td><td>60Hz</td><td>clock</td><td>no</td><td>yes</td></tr> <tr><td>#+11</td><td>50Hz</td><td>clock</td><td>no</td><td>yes</td></tr> <tr><td>#+12</td><td>60Hz</td><td>clock backup</td><td>yes</td><td>yes</td></tr> <tr><td>#+13</td><td>50Hz</td><td>clock backup</td><td>yes</td><td>yes</td></tr> <tr><td>#+14</td><td>60Hz</td><td>clock</td><td>yes</td><td>yes</td></tr> <tr><td>#+15</td><td>50Hz</td><td>clock</td><td>yes</td><td>yes</td></tr> </tbody> </table>	Entry	AC Freq.	Crystal for	AC Loss disp	Clock disp	0	60Hz	clock backup	no	no	1	50Hz	clock backup	no	no	2	60Hz	clock	no	no	3	50Hz	clock	no	no	4	60Hz	clock backup	yes	no	5	50Hz	clock backup	yes	no	6	60Hz	clock	yes	no	7	50Hz	clock	yes	no	8	60Hz	clock backup	no	yes	9	50Hz	clock backup	no	yes	#+10	60Hz	clock	no	yes	#+11	50Hz	clock	no	yes	#+12	60Hz	clock backup	yes	yes	#+13	50Hz	clock backup	yes	yes	#+14	60Hz	clock	yes	yes	#+15	50Hz	clock	yes	yes
Entry	AC Freq.	Crystal for	AC Loss disp	Clock disp																																																																																			
0	60Hz	clock backup	no	no																																																																																			
1	50Hz	clock backup	no	no																																																																																			
2	60Hz	clock	no	no																																																																																			
3	50Hz	clock	no	no																																																																																			
4	60Hz	clock backup	yes	no																																																																																			
5	50Hz	clock backup	yes	no																																																																																			
6	60Hz	clock	yes	no																																																																																			
7	50Hz	clock	yes	no																																																																																			
8	60Hz	clock backup	no	yes																																																																																			
9	50Hz	clock backup	no	yes																																																																																			
#+10	60Hz	clock	no	yes																																																																																			
#+11	50Hz	clock	no	yes																																																																																			
#+12	60Hz	clock backup	yes	yes																																																																																			
#+13	50Hz	clock backup	yes	yes																																																																																			
#+14	60Hz	clock	yes	yes																																																																																			
#+15	50Hz	clock	yes	yes																																																																																			
*182	Summer Time Switchover Day 0 = switch on Sunday morning 1 = switch on Saturday morning 2 = switch on Friday morning	Select the appropriate summer time switchover day.																																																																																					
*183	Date/Time Format 0 = 12-hour time/MMDDYY date 1 = 12-hour time/DDMMYY date 2 = 24-hour time/MMDDYY date 3 = 24-hour time/DDMMYY date	Select the desired time and date format.																																																																																					
*185	Downloader Suppression Options 0 = no suppression 1 = suppress user code viewing 2 = suppress commands and program download when armed 3 = suppress user code viewing, commands, and program download when armed	Select the desired options.																																																																																					

FIELD	TITLE and DATA ENTRIES	EXPLANATION
*186	Display Options Entry 1: Latch first alarm in the display 0 = disable; 1 = enable Entry 2: Blank the display (except for AC loss) when not in exit delay, or 30 seconds after disarm 0 = disable; 1 = enable	Select the desired keypad display options. Entry 1: If enabled, only the first zone that went into alarm is displayed. Pressing the READY key will scroll once through the other zones that went into alarm, then the first zone in alarm will again be displayed.
*187	Sounder Mimic on Trigger 1 0 = no sound output on trigger 1 1 = mimic keypad 1, address 16 2 = mimic keypad 2, address 17 3 = mimic keypad 3, address 18 4 = mimic keypad 4, address 19 5 = mimic keypad 5, address 20 6 = mimic keypad 6, address 21 7 = mimic keypad 7, address 22 8 = mimic keypad 8, address 23	Enable this option if you want an external device connected to trigger 1 to mimic keypad sounding. NOTE: If using this option, trigger 1 must be dedicated to only this function; do not assign any other functions to trigger 1.
*188	Keypad Sabotage Options Entry 1: Keypad Lockout: 0 = disable; 1 = enable 15 minute lockout Entry 2: Keypad Supervision and Tamper Fault Detection: 0 = no, 1 = yes	Entry 1. If selected, will lockout the keypad for 15 minutes if 30 keystroke entries (6 attempts of code + command) are made without a valid user code being detected. While the keypad is locked out, a message "Code Sabotage" will be displayed on the keypads in the partition that is locked out. A message will be transmitted to the central station (461 Wrong Code Entry) if Contact ID format is selected as reporting format in field *48 (if Contact ID format is not being used, this event is not reported). The Wrong Code Entry is always logged in the event log. Entry 2. Enables or disables keypad supervision (ECP addresses 16-23) in the control. If selected, keypads are supervised for connection and tamper. These conditions cause a trouble when disarmed, alarm when armed.

AUI Enable

FIELD	TITLE and DATA ENTRIES	EXPLANATION
*189	<p>AUI Device 1 and 2 Enable (for Touch Screen Style Keypads)</p> <p>0 = disabled 1 = partition 1 2 = partition 2 3 = common partition</p> <div style="border: 1px solid black; padding: 2px; width: fit-content;"> <p>NOTE: Use of AUI does not affect the number of standard keypads supported.</p> </div>	<p>The System supports up to two touch screen style keypads (e.g., Symphony Advanced User Interface, and 6270 Touch Screen Keypad). Enter each AUI's home partition.</p> <div style="border: 1px solid black; padding: 2px; width: fit-content;"> <p>AUI Compatibility Note: To ensure proper AUI device operation, use AUI devices with the following rev levels: 6270 series use version 1.0.9 or higher; 8132/8142 (Symphony) series use version 1.1.175 or higher.</p> </div> <p>Touch Screen (AUI) device 1: Must set AUI device address to 1 Touch Screen (AUI) device 2: Must set AUI device address to 2</p>

Keypad Programming Fields

NOTE: Each keypad must be assigned a unique address. Keypads programmed with the same address will give unpredictable results.

FIELD	TITLE and DATA ENTRIES	EXPLANATION
*190	<p>Keypad 2 Device Address 17</p> <p>Entry 1 – Partition Assignment: 0 = keypad disabled 2 = partition 2 1 = partition 1 3 = common</p> <p>Entry 2 – Sound Option: 0 = no suppression 1 = suppress arm/disarm and E/E beeps 2 = suppress chime beeps only 3 = suppress arm/disarm, E/E beeps and chime beeps</p>	<p>Keypad 2 Entry 1: enter the partition in which the keypad is located</p> <p>Entry 2: Enter the desired sound option for this keypad.</p> <p>NOTE: Address 16 is reserved for keypad 1, which is factory set to partition 1 with all sounds enabled.</p>
*191	<p>Keypad 3 Device Address 18 See field *190 for entries.</p>	<p>Keypad 3 See field *190 for explanation.</p>
*192	<p>Keypad 4 Device Address 19 See field *190 for entries.</p>	<p>Keypad 4 See field *190 for explanation.</p>
*193	<p>Keypad 5 Device Address 20 See field *190 for entries.</p>	<p>Keypad 5 See field *190 for explanation.</p>
*194	<p>Keypad 6 Device Address 21 See field *190 for entries.</p>	<p>Keypad 6 See field *190 for explanation.</p>
*195	<p>Keypad 7 Device Address 22 See field *190 for entries.</p>	<p>Keypad 7 See field *190 for explanation.</p>
*196	<p>Keypad 8 Device Address 23 See field *190 for entries.</p>	<p>Keypad 8 See field *190 for explanation.</p>

FIELD	TITLE and DATA ENTRIES	EXPLANATION
*197	Exit Time Display Interval 0 = no display 1-5 = seconds between display refreshing	If enabled, keypads display the exit delay time remaining after arming the system, with display updates at the interval selected (i.e. if the exit delay is 30 seconds and "2" is selected in this field, the keypad display refreshes every 2 seconds, displaying 30, 28, 26, 24, etc.). An interval greater than "1" may be necessary for some older keypads to allow users time to enter key presses between display updates.
*198	Display Partition Number 0 = no 1 = yes	If selected, the partition number is displayed in the upper-left corner of the display. This is useful when using the GOTO partition function.
*199	ECP Device Fail Display 0 = 3-digit display ("1" + device address) 1 = 2-digit fixed-display as "91"	Select "0" if using Alpha keypads and/or 3-digit Fixed-Word Display keypads (6148, 6150, 6160, 6164). ECP faults for keypads and/or other peripheral ECP devices will display "1" plus the device address (00-30) of device causing the fault (e.g., faults on device 07 display as "107"). Select "1" if using 2-digit Fixed-Word Display keypads (e.g., certain 6128RF series keypads). If selected, ECP faults for keypads and/or peripheral devices will display as "91" on 2-digit displays, and "191" on 3-digit or Alpha keypads.

Menu Mode Programming

About Zone Programming (*56 and *58 Menu Modes)

*56 Zone Programming is used to program zones, zone types, report codes, enroll 5800 RF Wireless Transmitter serial numbers, and identify the type of loop input device(s). This mode can also be used to enter alpha descriptors for programmed zones; however, we recommend entering descriptors in menu mode *82 (*Alpha Descriptor Programming* after all zone programming has been completed). For a faster method of zone programming, you can use the *58 Expert Programming Mode instead of *56 Zone programming. The *58 Expert Programming Mode is designed for those who have had previous experience in programming control panels of this type.

NOTE: Alpha display prompts are shown in a double-line box.

*56 Zone Programming Procedure

Zone Programming involves:

1. Entering the zone number to be programmed;
2. Making appropriate entries at the prompts;
3. Confirming the serial number of wireless transmitter zones.

Start Zone Programming mode by pressing *56 while in Data Programming mode. The following prompts are displayed:

PROMPT	VALID ENTRIES	EXPLANATION
SET TO CONFIRM? 0 = NO 1 = YES	Set to Confirm 0 = no 1 = yes	If 1 (Yes) is entered, the XMIT TO CONFIRM prompt appears later in this procedure after entering RF transmitter serial and loop numbers, and lets you confirm the programming of each RF transmitter. We recommend that you confirm every transmitter. If 0 (No) is entered, the XMIT TO CONFIRM prompt is automatically skipped. This option is ignored if programming wired zones only.
Enter Zn Num. (00 = Quit) 17	Zone Number wired zones 01-06, aux wired zones 17-24 wireless zones 09-24 RF button zones 49-64 91 = addr. device report enable 92 = duress report enable 95, 96, 99 =emergency zones 00 to quit [*] to continue	Enter the zone number that you wish to program. Zone 17 has been entered as an example in the display at left. Enter a report code for zone 91 to enable addressable device reporting. Enter a report code for zone 92 to enable duress reporting. 95, 96, 99 are emergency (panic) key zones.

17 HARDWIRE TYPE
EOL 0

Basic Wired Type
 0 = EOL; 1 = NC; 2 = NO
 3 = zone doubling (ZB)
 4 = double-balanced (DB)
 [*] to continue

This prompt appears only for zone numbers 01-06.
 Zone 1 is automatically set for EOL operation.

PROMPT	VALID ENTRIES	EXPLANATION		
<table border="1"> <tr> <td>02 Response Time</td> </tr> <tr> <td> 1</td> </tr> </table>	02 Response Time	1	<p>Response Time (RT) 0 = 10mSec 2 = 700mSec 1 = 400mSec 3 = 1.2 seconds [*] to continue</p>	<p>This prompt appears only for basic wired zones 01-06 (zone 02 is used as an example in display). NOTE: If zone doubling is being used, the response time set for zones 01-06 automatically applies to each zone's associated doubled zone.</p>
02 Response Time				
1				

17 INPUT TYPE	
RF TRANS	3

Input Device type (In)

- 2 = AW (Aux wired zone)
- 3 = RF (supervised RF transmitter,
- 4 = UR (unsupervised RF transmitter)
- 5 = BR (unsupervised button type RF transmitter)
- 7 = RM (supervised RF motion detector)

[*] to continue

This prompt is skipped for zones 09-14 if zone-doubling was enabled at “Hardwire Type” prompt. All of the RF transmitters have one or more unique factory-assigned input (loop) ID codes. Each of the inputs requires its own programming zone (e.g., a 5804’s four inputs require four programming zones). RF Transmitters can be enrolled as one of the following types:

Type and Description

“RF” (Supervised RF): Sends periodic check-in signals, as well as fault, restore, and low-battery signals. The transmitter must stay within receiver’s range.

“UR” (Unsupervised RF): Sends all the signals that the “RF” type does, but the control does not supervise the check-in signals. The transmitter may therefore be carried off-premises.

“BR” (Unsupervised Button RF): Sends only fault signals. It does not send a low-battery signal until it is activated. The transmitter may be carried off-premises.

“RM” (Supervised RF Motion Detector): Sends periodic check-in signals, as well as fault and low-battery signals. The panel ignores detector restore signals but automatically restores the zone to “ready” after a few seconds. Intended for facilities with multiple motion detectors that may fault and restore simultaneously. The transmitter must remain within the receiver’s range.

RM NOTE: While the system is disarmed, faults from input type RM devices might not be seen on the keypad display because the automatic restore can occur more quickly than the display is refreshed.

NOTES:

- For the built-in basic wired zones, the Input Device type is automatically displayed as HW and cannot be edited.
- To change the input type of a previously programmed wireless device (type RF, UR, BR, RM) to a wired zone (type AW), you must first delete the transmitter’s serial number

PROMPT	VALID ENTRIES	EXPLANATION
<pre> 17 INPUT S/N: L A022-4064 1 </pre>	Serial number Entry and Loop Number Entry see explanation [*] to continue	<p><i>Used only when enrolling wireless transmitters.</i></p> <ol style="list-style-type: none"> Transmit two open/close sequences. If using a button-type transmitter, press and release the button twice, but wait about 4 seconds before pressing the button the second time. <p>OR</p> <ol style="list-style-type: none"> Manually enter the 7-digit serial number printed on the label of the transmitter. Then press the [*] key – the cursor will move to the “L” position. You can edit the loop number, if necessary. When the loop number is acceptable, press [*]. Press key [C] to copy the serial number previously enrolled (used when programming a transmitter with several input loops).
<pre> 17 INPUT S/N L A022-4064 ? </pre>	Loop Number Change [*] to continue	<p>NOTE: If the [C] key is used to copy the previously enrolled serial number, the cursor will move to the Loop column (L) with the previous serial number displayed, and display a highlighted question mark for the loop number.</p> <p>Enter the loop number and press [*]. The system will now check for a duplicate serial/loop number combination.</p>
<pre> 17 INPUT S/N L A022-4064 1 </pre>	Enroll Summary [*] to continue	<p>If the serial/loop number combination is not a duplicate in the system, a display showing the serial number and loop number entry will appear.</p> <p>To Delete an Existing Serial Number: Enter 0 in the loop number field. The serial number will change to 0's.</p> <pre> 10 INPUT S/N: L A000-0000 0 </pre> <p>If 0 was entered in error, simply re-enter the loop number or press [#], and the serial number will return to the display.</p>

PROMPT	VALID ENTRIES	EXPLANATION
XMIT TO CONFIRM PRESS * TO SKIP	Confirmation Option Activate the loop input or button [*] to continue	This prompt will only appear if you answered “Yes” at the first prompt in this section. The system will enter a confirmation mode so that the operation of the actual programmed input can be confirmed. Activate the loop input or button that corresponds to this zone. If the serial number and/or loop number transmitted does not match the serial number entered, a display similar to the one below appears. <div style="border: 1px solid black; padding: 5px; margin: 10px 0;"> Entd A022-4063 1 Rcvd A022-4064 1 </div> If so, activate the loop input or button on the transmitter once again. If a match is not obtained (i.e., summary display does not appear), press the [#] key twice and then enter (or transmit) the correct serial number. Press [*] to continue.
Zn ZT RC In: L 17 03 10 RF: 1s	Summary Screen [*] to continue	If the serial number transmitted matches the serial number entered, the keypad will beep 3 times and a summary display will appear, showing that zone’s programming. Note that an “s” indicates that a transmitter’s serial number has been enrolled. Press [*] to accept the zone information and continue.
PROGRAM ALPHA? 0 = NO 1 = YES 0	Alpha Descriptors 0 = no 1 = yes [*] to continue	If you want to program descriptors for zones now, enter 1 (Yes) and refer to the <i>Alpha Descriptor Programming</i> section for the procedure to use.
ENTER ZN NUM. (00 = QUIT) 11	Next Zone Number 00 = quit [*] to continue	If 0 (No) was entered above, the system will return you to the ENTER ZN NUM. prompt for the next zone. When all zones have been programmed, enter 00 to quit.

Completing Zone Programming

When you have finished programming all zones, test each zone using the system’s TEST mode. **Do not use the Sensor Sniffer Mode for checking wireless transmitting devices**, as it will only check for transmission of one zone on a particular transmitter, NOT the zones assigned to each additional loop.

NOTE: Following the successful enrollment of each wireless device, note the device serial number in the appropriate column on the ENROLLED TRANSMITTERS worksheet in the Programming Form; then enter the other information (zone number, zone type, loop number, etc.) relevant to that device.

*58 Expert Programming Mode Procedures

This method is designed for use by installers with previous experience in programming ADEMCO control panels. This mode is also used to program wireless keys using pre-defined templates.

Start Expert Programming mode by pressing *58 while in Data Programming mode. The following prompts are displayed:

PROMPT	VALID ENTRIES	EXPLANATION
<pre> SET TO CONFIRM? 0 = NO 1 = YES 0 </pre>	<p>Confirm? 0 = no 1 = yes [*] to continue</p>	<p>If 1 (Yes) is entered, the XMIT TO CONFIRM prompt appears later in this procedure after entering RF transmitter serial and loop numbers, and lets you confirm the programming of each RF transmitter. We recommend that you confirm every transmitter.</p> <p>If 0 (No) is entered, the XMIT TO CONFIRM prompt is automatically skipped.</p> <p>This option is ignored if programming wired zones only.</p>
<pre> Zn ZT P RC HW: RT 01 09 1 10 EL 1 </pre> <pre> Zn ZT P RC IN: L 10 - - - : - </pre>	<p>Summary Screen 01-06, 9-24, 49-64 = zone number 00 = quit [*] to continue</p> <p>OR</p> <p>[D] to go to prompts for wireless key programming templates</p>	<p>A summary screen will appear, showing zone 1's currently programmed (or default) values.</p> <p>Enter the zone number being programmed, then press [*], which displays a summary screen for that zone. See next prompt (in this example, zone 10 is being entered).</p> <p>If programming a wireless key, press the [D] key then skip to the Wireless Key Programming Templates section following this section. When [D] is pressed, you can choose from a series of preset templates for easy programming of wireless key zones.</p> <p>When all zones have been programmed, press "00" at this prompt to quit this menu mode.</p>

PROMPT	VALID ENTRIES	EXPLANATION
<pre> Zn ZT P RC IN: L 10 00 1 10 RF 1 </pre>	<p>Zone Programming ZT = see Zone Type chart shown in *56 Menu Mode "Zone Type" prompt P = partition 1, 2, 3 (common) RC = 0-9 (cannot enter hex report codes; use *56 mode to enter hex codes) IN = input type L = loop number</p>	<p>A summary screen with the selected zone's current programming appears.</p> <p>Begin programming zone information as follows:</p> <ul style="list-style-type: none"> • Enter Zone Type (ZT), Partition (P), Report Code (RC), and Input Device Type (IN)* sequentially, but not the Loop No. (L). • Use the [A] (Advance) and [B] (Back) keys on the keypad to move the cursor within the screen. • Use the [C] key to copy the previous zone's attributes. <p>Press [*] to save the programming and continue to the serial number/loop number prompt. If needed, you can press the [#] key to back up without saving.</p> <p>* If HW (basic wired) or AW (Auxiliary) is entered for Input Device Type, the next screen will be similar to the prompt shown, except that HW or AW will be displayed under "IN".</p> <p>If RF, BR, or UR is entered, a prompt for Serial and Loop number will be displayed, as follows.</p>
<pre> 10 INPUT S/N: L AXXX-XXX - </pre>	<p>Serial number S/N = serial number L = loop number</p>	<p>Manually enter the serial number (found on the transmitter label), by typing digits in the "X" locations, using the [A] (advance) or [B] (back) keys as required. You can also perform two open and close sequences; for button-type transmitters that means pressing and releasing the button twice.</p> <p>NOTE: If you want to copy the previous zone's serial number, press the [C] key.</p> <p>Press [*] to advance to the loop number, then enter loop number.</p> <p>Press [*] to accept the existing serial and loop number and continue to the "Confirm" prompt below. If necessary, press [#] to back up and re-enter or edit the serial number.</p>
<pre> 10 INPUT S/N: L A000-0000 0 </pre>	<p>To Delete a Serial Number [*] to continue</p>	<p>To delete an existing serial number, enter 0 in the loop number field. The serial number will change to all 0's as shown.</p> <p>If 0 was entered in error, simply re-enter the loop number, and the serial number will return to the display.</p>

PROMPT	VALID ENTRIES	EXPLANATION
<div style="border: 1px solid black; padding: 5px; width: fit-content;"> 10 XMIT TO CONFIRM PRESS * TO SKIP </div>	Confirm [*] to continue	<p>The prompt to confirm appears. This prompt will only appear if the first prompt after entering *58 was answered "Yes." To confirm, activate the loop input or button that corresponds to this zone. The system checks for a duplicate. If a duplicate exists, a long error beep will sound. Press [#] to back up and re-enter the serial and/or loop number.</p>
<div style="border: 1px solid black; padding: 5px; width: fit-content;"> Entd A022-4063 Rcvd A022-4064 </div>	If Serial or Loop Numbers do not match after activating the transmitter [*] to continue	<p>If the serial/loop number combination transmitted does not match the serial and loop number entered, a display similar to the one below will appear. If the loop number does not match, it will also be displayed. If so, activate the transmitter's loop input or button one or more times. If a match is still not obtained (i.e., summary display does not appear), press the [#] key twice and enter the correct loop input or, if correct, press [#] again and then enter the correct serial number.</p>
<div style="border: 1px solid black; padding: 5px; width: fit-content;"> Zn ZT P RC In L 10 03 1 10 RF:1s </div> <p>Note that an "s" indicates that a transmitter's serial number has been enrolled.</p>	Summary Screen [*] to continue	<p>If the serial number transmitted matches the serial number entered, the keypad will beep 3 times and a summary display will appear, showing the programmed information for that zone.</p> <p>Press [*] to begin programming the next zone. See first "Summary Screen" prompt paragraph on previous page.</p>

Wireless Key Programming Templates

This procedure programs the wireless keys, **but a key is not active until it is assigned to a user number** (see *System Operation* section, assigning attributes command).

If the D key was previously pressed (from *58 Menu mode) to enter and duplicate 5804 and/or 5804BD wireless keys, the following screens appear.

PROMPT	VALID ENTRIES	EXPLANATION
<div style="border: 1px solid black; padding: 5px; width: fit-content;"> TEMPLATE ? 1-6 1 </div>	Template Number 1-3 = 5804 templates 4-6 = 5804BD templates [*] to continue	<ol style="list-style-type: none"> Enter Template number 1-6 (from next page). See the defaults provided for each template in the chart that follows these procedures. Select from templates. Press [*] to display template (1 shown selected). NOTE: If necessary, press [#] to back up and re-enter template number. Press [#] if you want to return to zone attributes screen.

PROMPT	VALID ENTRIES	EXPLANATION										
<div style="border: 1px solid black; padding: 5px; display: inline-block;"> <table style="width: 100%; border-collapse: collapse;"> <tr> <td style="width: 10%;">L</td> <td style="width: 10%;">01</td> <td style="width: 10%;">02</td> <td style="width: 10%;">03</td> <td style="width: 10%;">04</td> </tr> <tr> <td>T</td> <td>23</td> <td>22</td> <td>21</td> <td>23</td> </tr> </table> </div>	L	01	02	03	04	T	23	22	21	23	<p>Template Display [*] to continue</p>	<p>4. When [*] is pressed, the selected template will be displayed. Top line of display represents loop numbers, bottom line represents zone type assigned for each loop.</p> <p>5. Press [*] to accept template.</p>
L	01	02	03	04								
T	23	22	21	23								
<div style="border: 1px solid black; padding: 5px; display: inline-block;"> <table style="width: 100%; border-collapse: collapse;"> <tr> <td style="width: 80%;">PARTITION</td> <td style="width: 20%; text-align: center;">1</td> </tr> </table> </div>	PARTITION	1	<p>Partition 1 = partition 1 2 = partition 2 3 = partition 3 [*] to continue</p>	<p>6. Enter the partition in which the key is to be active.</p> <p>7. Press [*] to continue.</p>								
PARTITION	1											
<div style="border: 1px solid black; padding: 5px; display: inline-block;"> <table style="width: 100%; border-collapse: collapse;"> <tr> <td colspan="2">ENTER START ZONE</td> </tr> <tr> <td style="width: 50%;">00 = QUIT</td> <td style="width: 50%; text-align: right;">36</td> </tr> </table> </div>	ENTER START ZONE		00 = QUIT	36	<p>Start Zone Number [*] to continue</p>	<p>8. The system will search for the highest available consecutive 4-zone group (the four zones in the case of the 5804 and 5804BD), and display the lowest zone number of the group.</p> <p>If you want to start at a different zone, enter the zone desired, and press [*]. If that zone number is displayed, the system has the required number of consecutive zones available, beginning with the zone you entered. If not, the system will again display a suggested zone that can be used.</p> <p>If the required number of consecutive zones is not available at all, the system will display "00".</p> <p>9. Press [*] to accept.</p>						
ENTER START ZONE												
00 = QUIT	36											
<div style="border: 1px solid black; padding: 5px; display: inline-block;"> <table style="width: 100%; border-collapse: collapse;"> <tr> <td style="width: 80%;">INPUT S/N</td> <td style="width: 20%; text-align: center;">L</td> </tr> <tr> <td>AXXX-XXXX</td> <td style="text-align: center;">-</td> </tr> </table> </div>	INPUT S/N	L	AXXX-XXXX	-	<p>Serial Number [*] to continue</p>	<p>10. Manually enter the serial number printed on the label for the wireless key or press and release the button to transmit its serial number.</p> <p>11. Press [*] to accept the serial number. The system will check for duplicate.</p> <p>12. If necessary, press the [#] key to back up without saving, and re-enter the serial number.</p> <p>Use the [A] key to move forward within the screen, and the [B] key to move backward.</p>						
INPUT S/N	L											
AXXX-XXXX	-											

PROMPT	VALID ENTRIES	EXPLANATION
<div style="border: 1px solid black; padding: 5px; width: fit-content;"> XMIT TO CONFIRM PRESS * TO SKIP </div>	Confirm [*] to continue	<p>13. If “Yes” was entered at the SET TO CONFIRM? prompt previously (see first prompt following entry into the •58 Expert Programming Mode), the display on the left will appear. Confirm serial and loop numbers by activating the wireless key.</p> <p>IMPORTANT: When confirmed, the key is not active until it is assigned to a user number (using the assigning attributes command, attribute “4”). See <i>System Operation</i> section for procedure.</p>
<div style="border: 1px solid black; padding: 5px; width: fit-content;"> Entd A022-4063 Rcvd A022-4064 </div>	Not Confirmed [*] to continue	<p>If the serial number transmitted does not match the serial number entered, a display similar to the one shown will appear. If the loop number does not match, it will also be displayed. If so, activate the button on the wireless key once again. If a match is not obtained (i.e., summary display does not appear), press the [#] key and then enter the correct serial number.</p> <p>If the serial number transmitted matches the serial number entered, the keypad will beep 3 times and will return you to step 8 to enter the starting zone for the next wireless key.</p> <p>NOTE: Following the successful enrollment of each wireless device, remove ONE of the serial number labels from the device and affix it in the appropriate column on the ENROLLED TRANSMITTERS worksheet of the Programming Form; then enter the other information (zone number, zone type, loop number, etc.) relevant to that device.</p>

Wireless Key Predefined Default Templates

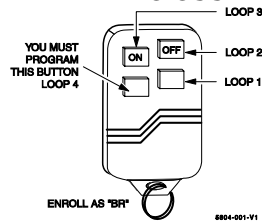

5804 Wireless Key Transmitter

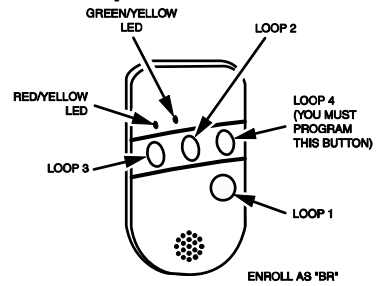

5804BD 2-Way Wireless Key Transmitter

For 5804				For 5804BD			
TEMPLATE 1	Loop	Function	Zone Type	TEMPLATE 4	Loop	Function	Zone Type
	1	No Response	23		1	No Response	23
	2	Disarm	22		2	No Response	23
	3	Arm Away	21		3	Arm Away	21
	4	No Response	23		4	Disarm	22
TEMPLATE 2	Loop	Function	Zone Type	TEMPLATE 5	Loop	Function	Zone Type
	1	No Response	23		1	No Response	23
	2	Disarm	22		2	Arm Stay	20
	3	Arm Away	21		3	Arm Away	21
	4	Arm Stay	20		4	Disarm	22
TEMPLATE 3	Loop	Function	Zone Type	TEMPLATE 6	Loop	Function	Zone Type
	1	24-hour audible	7		1	24-hour audible	7
	2	Disarm	22		2	Arm Stay	20
	3	Arm Away	21		3	Arm Away	21
	4	Arm Stay	20		4	Disarm	22

About Output Device Programming (*79/*80 Menu Mode)

Output Devices: The system supports up to 4 relays and/or Powerline Carrier devices (X-10 devices) plus 2 built-in trigger outputs in any combination. These 6 “outputs” are assigned to system-wide output numbers (01-06 and 17-18). Use *79 Menu Mode to assign output numbers and map them to device addresses.

Output Functions: The system also provides up to 12 installer-defined output functions, which can be assigned to any of the physical outputs. Therefore, the action of any one of the outputs can be based on as many of these functions as desired. This lets a single relay or X-10 device perform many functions. Use *80 Menu Mode to define output functions.

NOTE: When navigating the *79 and *80 menus: The [*] key is used to accept an entry and advance to the next prompt. The [#] key is used to revert back to the last question to check or change an entry. Press [*] to go forward again.

Output Device programming involves:

1. Use *79 Menu Mode to assign module and output numbers and map them to device addresses.
NOTE: You must map output devices using *79 Menu Mode **before** you can use *80 Menu Mode.
2. Use *80 Menu Mode to create output definitions, which control the output devices.

*79 Menu Mode: Output Device Mapping

Use this menu to assign Relay Module device addresses and specific relay numbers, and Powerline Carrier unit numbers. The system is based on predefined module addresses for 4204 and 4229 modules. Refer to the table shown at the “Module Address” prompt on the next page and set the modules’ addresses (via module DIP switches) accordingly.

The following table shows how these outputs are identified.

Output Identification

This output...	is identified by...
Relays:	the Relay Module’s device address and the relay position on that module (i.e. the physical relay number, 1-4, on that module).
X-10 Device	a house ID (entered in data field *27) and the unit number of the device.
Built-in Outputs	the output number assigned, 17 for trigger 1 and/or 18 for trigger 2.

Start Output Device Mapping by pressing *79 while in Data Programming Mode. The following prompts are displayed:

*

*80 Menu Mode: Defining Output Functions

Use this mode to program output function definitions (up to 12 functions) that provide automated control of any of the output devices, based on events occurring on individual zones or zones with certain zone types. Each output definition is identified by an output function number, and includes the following components:

Output Definition Components

Component	Description
Output Function No.	A reference number that defines an output's characteristics.
Activated By	Determines whether the initiating event occurs on a zone, a zone list, or a zone type.
Event	Event that triggers the output action. Can be an event occurring on a specific zone number or a zone list or a specific zone type.
Partition	If the output is activated by zone type, this defines the partition in which the programmed event is to cause the device action.
Output Action	Defines the action of the relay/X-10 device when the defined event occurs. Can close for 2 seconds, stay closed until reset, continuously pulse (1-second close-open-close-open, etc.), toggle the device state, or activate for a defined duration (set in data field *177).
Output No.	Assigns this function to a specific output number (defined in *79 Menu Mode). This is the output number that will perform this function upon the triggering event. Note that each defined function is associated with only one output number. This means that if more than one output device needs to perform this particular function, you need to define another output function number with the same attributes, but assign the appropriate output number. (i.e. output devices can be assigned more than one function number, but each function number can only be assigned a single output number.

For example, if you want to pulse a strobe light upon fire alarms on zone 4 using a relay mapped to output number 2 (as programmed in *79 Menu Mode), program the following in *80 Menu Mode:

Prompt	Entry
Output Funct. #	= 01 (assuming this is the first output function)
Activated By:	= 3 (zone number)
Enter Zn No.	= 04 (requires 2-digit zone numbers)
Output Action	= 3 (continuous pulse)
Output Number	= 02 (device mapped in *79 Menu Mode)

Start Output Definition mode by pressing *80 while in Data Programming mode. The following prompts are displayed:

*80 Menu Mode

PROMPT	VALID ENTRIES	EXPLANATION
Output Funct. # (00 = Quit) 01	Output Function No. 01-12 = output function number [*] to continue	Enter the output function number to be defined (or 00 to exit).

PROMPT	VALID ENTRIES	EXPLANATION
<pre>01 A E P Trig ?00 0 0 - ZL=1</pre>	<p>Summary Screen [*] to continue</p>	<p>This screen displays a summary of the current output programming (for this example, Zone List has been selected-this is the default screen).</p> <p>A = Output Action; E = Triggering event; P = Partition; Trig = Trigger type</p> <p>NOTE: A question mark in the summary screen indicates that the device number shown has not been mapped. Use *79 Menu mode to map the device.</p>
<pre>01 Activated By: Zone List</pre>	<p>Activated By 0 = delete 1 = zone list 2 = zone type 3 = zone number [*] to continue</p>	<p>Select where the initiating event for this output definition is to occur as follows:</p> <p>0 = delete (deletes the output function and any previous programming;-see prompt below) 1 = zone list (go to "A" prompt) 2 = zone type (go to "B" prompt) 3 = zone number (go to "C" prompt)</p> <p>If you enter "0," the following prompt appears:</p> <pre>Delete? 0 = NO, 1 = YES</pre> <p>Press 1 to delete this output definition.</p>
<p>"A"</p> <pre>01 Zn List 1</pre>	<p>Zone List 01-12 = zone list [*] to continue</p>	<p>If zone list was selected, this screen appears. Otherwise skip to the next row.</p> <p>Enter the desired zone list number associated with this output number.</p> <p>NOTE: Zone lists 09-12 can be used in output definitions if not used for paging or for exit zone definition.</p> <p>Press [*] to continue.</p> <p>Enter the zone list event that will activate this output.</p> <pre>Enter Event Alarm 11</pre> <p>0 = restore; 1 = alarm; 2 = fault; 3= trouble</p> <p>NOTE: For alarm, fault, and trouble, an event on ANY zone in the list activates the output.</p> <p>Press [*] to continue and skip to the "Output Action" prompt.</p>

PROMPT	VALID ENTRIES	EXPLANATION
--------	---------------	-------------

“B”

01 Enter Zn type	
Perimeter	03

Zone Type
see list at right

If zone type was selected, this screen appears. Otherwise skip to the next row.

Enter the desired zone type associated with this output number. See below for a list of available zone types.

CHOICES FOR ZONE TYPES:

- | | | |
|------------------------|------------------------------|--------------------------|
| 00 = Not Used | 05 = Trouble Day/Alarm Night | 15 = Medical |
| 01 = Ent/Exit #1 | 06 = 24 Hr Silent | 16 = Fire w/verification |
| 02 = Ent/Exit #2 | 07 = 24 Hr Audible | 23 = No Alarm Response |
| 03 = Perimeter | 08 = 24 Hr Aux | 24 = Silent Burglary |
| 04 = Interior Follower | 09 = Fire | 77 = Keypad |
| | 10 = Interior w/Delay | 81 = AAV Monitor Zone |
| | 12 = Monitor Zone | 82 = Blockschloss |
| | 14 = Gas | 90-93 = Configurable |

CHOICES FOR SYSTEM OPERATION:

- | | | |
|----------------------------|-------------------------|-----------------------------------|
| 20 = Arming-Stay | 41 = **AC Mains Failure | 67 = Siren Fail |
| 21 = Arming-Away | 42 = **System Batt Low | 68 = Telecom Line Cut |
| 22 = Disarming | 43 = Comm. Failure | 69 = Telecom Line Restore |
| | 46 = Sys Batt Restore** | 70 = AC Mains Restore** |
| 31 = End of Exit Time | 52 = Kissoff | 71 = System Startup/Clock Not Set |
| 32 = Start of Entry Time | | 72 = Clock Set |
| 33 = Any Burglary Alarm | 54 = Fire Zone Reset | 78 = Keypad Red LED |
| 36 = **At Siren Timeout*** | 58 = Duress | 79 = Keypad Green LED |
| 38 = Chime | 60 = AAV | 80 = Tamper Fault |
| 39 = Any Fire Alarm | 66 = Function Key† | |
| 40 = Bypassing | | |

** Use 0 (Any) for Partition No. (P) entry.

*** Or at Disarming, whichever occurs earlier.

† Use *57 Menu Mode to assign the function key (function “07”).

Note: In normal operation mode:

Code + # + 7 + NN Key Entry **starts** Device NN.

Code + # + 8 + NN Key Entry **stops** Device NN.

Enter the partition in which this zone type will occur.

01 Partition	
Any partition	0

0 = any partition; 1 = partition 1;
2 = partition 2; 3 = partition 3

Press [*] to continue and skip to the “Output Action” prompt.

PROMPT	VALID ENTRIES	EXPLANATION										
"C"												
01 Enter Zn No. 12	Zone Number	<p>If zone number was selected, this screen appears. Enter the desired zone number associated with this output number. Press [*] to continue. Enter the zone event that will activate this output.</p> <div style="border: 1px solid black; padding: 2px; display: inline-block; margin: 5px;"> 01 Enter Event Restore 0 </div> <p style="margin-left: 150px;">0 = restore; 1 = alarm 2 = fault; 3 = trouble</p> <p>Press [*] to continue to the "Output Action" prompt</p>										
01 Output Action Close for 2 sec 1	Output Action 0-6 = see list at right	<p>Enter the desired device action as listed below. Press the [*] key to continue.</p> <table style="width: 100%; border: none;"> <tr> <td style="width: 50%;">0 = off</td> <td style="width: 50%;">4 = Change</td> </tr> <tr> <td>Device State</td> <td></td> </tr> <tr> <td>1 = Close for 2 seconds</td> <td>5 = Duration 1 (see data field *177)</td> </tr> <tr> <td>2 = Close and Stay Closed</td> <td>6 = Duration 2 (see data field *177)</td> </tr> <tr> <td>3 = Continuous Pulse on & off (1 sec ON, 1 sec OFF)</td> <td></td> </tr> </table>	0 = off	4 = Change	Device State		1 = Close for 2 seconds	5 = Duration 1 (see data field *177)	2 = Close and Stay Closed	6 = Duration 2 (see data field *177)	3 = Continuous Pulse on & off (1 sec ON, 1 sec OFF)	
0 = off	4 = Change											
Device State												
1 = Close for 2 seconds	5 = Duration 1 (see data field *177)											
2 = Close and Stay Closed	6 = Duration 2 (see data field *177)											
3 = Continuous Pulse on & off (1 sec ON, 1 sec OFF)												
Enter Output No. R02 02	Output Number 01-04 = output no. 17-18 = on-board triggers	<p>Enter the device output number (programmed in *79 Menu Mode) you want associated with this output. Press [*] to continue.</p>										
02 A E P TRIG R02 1 1 3 ZL=1	Summary Screen	<p>A summary screen appears showing the programmed settings. Press [*] to continue.</p>										

About Zone Lists (*81 Menu Mode)

Zone lists let you group individual zones for use with certain system actions. The following table shows the available zone lists and their purposes:

List No.	Used for...
1,2	general purpose
3	chime-by-zone
4	linked zones
5	night-stay zones
6,7	general purpose
8	final contact set zones or general purpose
9	zones that activate pager 1 or general purpose
10	zones that activate pager 2 or general purpose
11	general purpose
12	exit zones (enabled in field *88)

Zone List Programming

Zone List programming involves:

1. Selecting an appropriate zone list number;
2. Adding the desired zone numbers to be included in that list.

Start Zone List Program Mode by pressing *81 while in Data Programming mode. The following prompts are displayed:

*81 Menu Mode

PROMPT	VALID ENTRIES	EXPLANATION
<div style="border: 1px solid black; padding: 5px;"> Zone List No. (00 = Quit) 01 </div>	Zone List Number 01-12 = zone list number [*] to continue	Enter the Zone List Number to program (or 00 to end these entries). Press [*] to advance. In the following displays, zone list 01 has been selected for programming.
<div style="border: 1px solid black; padding: 5px;"> 01 Enter Zn Num. (00 = Quit) 00 </div>	Zone Number 01-06, 9-24, 49-64 = zone numbers followed by [*] to accept each zone 00 to continue	Enter each zone number to add to the zone list, followed by pressing [*] (example, 01*, 02*, 03*). After all zones are entered, press 00 to continue. IMPORTANT: Do not include fire zones in zone lists that are used to STOP device actions.
<div style="border: 1px solid black; padding: 5px;"> 01 Del Zn List? 0 = No 1 = Yes 0 </div>	Deleting Zone Lists 0 = don't delete list 1 = delete this zone list [*] to continue	To delete the zone list, enter 1. All zones in the zone list will be deleted automatically and the system returns to the Zone List No. prompt. To save the zone list, enter 0.
<div style="border: 1px solid black; padding: 5px;"> 01 Delete Zone? 0 = No 1 = Yes 0 </div>	Deleting a Zone 0 = don't delete zones 1 = go to next prompt to delete zones [*] to continue	To save the entire zone list, enter 0 and the system returns to the Zone List No. prompt. To delete a zone or zones in a zone list enter 1 to continue.
<div style="border: 1px solid black; padding: 5px;"> 01 Zn to Delete? (00 = Quit) 00 </div>	Delete the Zone 01-06, 9-24, 49-64 zones to be deleted from list followed by [*] to accept each zone 00 to continue	Enter each zone to be deleted from the list, followed by [*]. After all zones to be deleted are entered, enter 00 to return to the Zone List No. prompt. so that another list can be programmed, if desired.

Notes:

- Any list may include any or all of the system's zone numbers.
- A zone list can be assigned to more than one output relay.
- When creating zone list 4 for linked zones, include only zones assigned to zone types 3, 4, or 5. Do not include zones that have delays (entry/exit zones, interior w/delay) or 24-hour zones, as these zone types may produce unpredictable operation and may not function as intended.

About Function Key Programming (*57 Menu Mode)

The system provides the ability to program each of the four keypad function keys to perform one of 12 system operations. The end user can then activate the function by simply pressing and holding the programmed key for 2 seconds. Typical functions (listed below) include single-button arming, turning lights on/off, or single-button paging.

Programming Function Keys

Function key programming involves:

1. Assigning the function key number and partition;
2. Selecting the desired function for that key.

Start Function Key Programming mode by pressing *57 while in Data Programming mode. The following prompts are displayed:

PROMPT	VALID ENTRIES	EXPLANATION
<div style="border: 1px solid black; padding: 5px;"> Press Key to Pgm 0 = Quit 0 </div>	<p>Function Key Press the desired function key, A-D.</p> <p>[*] to continue</p>	<p>Press the desired function key (A-D) you want to program.</p> <p>NOTE: A key programmed as a function key is no longer available to be used as an end-user macro key or panic key.</p> <p> A → <input type="text"/> <input type="text"/> 1 OFF <input type="text"/> 2 AWAY <input type="text"/> 3 STAY B → <input type="text"/> <input type="text"/> 4 MAX <input type="text"/> 5 TEST <input type="text"/> 6 BYPASS C → <input type="text"/> <input type="text"/> 7 INSTANT <input type="text"/> 8 CODE <input type="text"/> 9 CHECK D → <input type="text"/> <input type="text"/> * READY <input type="text"/> 0 <input type="text"/> # </p> <p style="text-align: right; font-size: small;">keypad_keys-00-001-V0</p>
<div style="border: 1px solid black; padding: 5px;"> Partition 1 </div>	<p>Partition Number 1 = partition 1 2 = partition 2 3 = partition 3</p> <p>[*] to continue</p>	<p>Enter the partition in which the function key is active.</p>

PROMPT	VALID ENTRIES	EXPLANATION
<div style="border: 1px solid black; padding: 5px; width: fit-content;"> Key "A" Func Zone 95 00 </div>	<p>Define Key Function 00-10 = see list to right [*] to continue Returns to key number prompt with the next function key letter displayed.</p> <p>† System defaults to these function key settings.</p> <p>For Options 09 and 10, note that there are only two macros per system. Therefore, be careful when assigning these macros to the various partitions.</p>	<p>Enter the desired function for this key, 00 to 12, from the options listed. (00 selected for example display shown at left)</p> <p>00† = For the Function key selected, the function will be as follows: If A selected = Zone 95 (emergency key, same as [1] [*] pair) If B selected = Zone 99 (emergency key, same as [*] [#] pair) If C selected = Zone 96 (emergency key, same as [3] [#] pair) If D selected = Single-button paging</p> <p>01 = Single-button paging (sends a 999-9999 message to pager) 02 = Display time 03 = Arm AWAY (reports as User 00 if closing reports are enabled) 04 = Arm STAY (reports as User 00 if closing reports are enabled) 05 = Arm NIGHT-STAY (reports as User 00 if closing reports are enabled) 06 = Step Arming (arms STAY, then NIGHT-STAY, then AWAY) 07 = Output Device Command (for device programmed as system operation type 66—function key in *80 Menu Mode) 08 = Communication Test (sends Contact ID code 601) 09 = Macro Key 1 (define macro by user code + [#] [6] [6] command) 10 = Macro Key 2 (define macro by user code + [#] [6] [6] command)</p>

About Descriptor Programming (*82 Menu Mode)

The system lets you directly enter zone descriptors for each protection zone so when an alarm or trouble occurs in a zone, an appropriate description for that zone's location can be displayed at the keypad. Each description is composed of up to 16 characters. In addition, you can enter three partition descriptors each composed of up to 16 characters.

NOTE: You can also enter zone descriptors when the zone is being defined in *56 Menu mode.

When defining descriptors:

- Pressing the [4] key moves cursor one space to the left.
- Pressing the [6] key accepts the entry and moves the cursor to the next position.
- Pressing the [8] key saves the entered descriptor and moves to the next descriptor.

Start Zone Descriptor Programming mode by pressing *82 while in Data Programming mode.

PROMPT	VALID ENTRIES	EXPLANATION
<div style="border: 1px solid black; padding: 5px; width: fit-content;"> Program Alpha ? 0=No, 1=Yes 00 </div>	<p>Program Alpha 0 = no 1 = yes [*] to continue</p>	<p>The "Program Alpha ?" prompt will appear. Press 1 to program zone descriptors or partition descriptors. Press 0 to exit.</p>

PROMPT	VALID ENTRIES	EXPLANATION
Sel Zone Des=0 Part/Rmndr=1	<p>Select Descriptor Type (Zone Descriptor or Partition Descriptor Words)</p> <p>0 = create zone descriptors (see Zone No? prompt below)</p> <p>1 = create partition descriptors [*] to continue</p> <p style="border: 1px solid black; padding: 2px;">Partition Descriptor Numbers: 11 = partition 1 descriptor 12 = partition 2 descriptor 13 = common partition descriptor</p>	<p>This prompt selects whether you are entering zone descriptors or entering partition descriptors. Pressing [0] goes to the next prompt to let you enter zone descriptors. Pressing [1] lets you program a partition descriptor. If selected, the following prompt appears:</p> <div style="border: 1px solid black; padding: 2px; width: fit-content; margin: 5px auto;">PART/REMINDE?</div> <p>Enter the 2-digit partition descriptor number (11-13) to be programmed, then press [*]. Enter the descriptor as described in steps 1-3 in the Zone Number section below.</p>
Zone No.? 00	<p>Zone Number</p> <p>Enter the desired zone number. [*] to continue.</p>	<p>After pressing [*], a cursor will appear at the second line.</p> <ol style="list-style-type: none"> Refer to the Character Chart below. Press [#], followed by the 3-digit entry for the first letter you want to display (e.g., # 0 6 5 for "A"). Press [6] to move the cursor to the right. Repeat Step 1 to enter the next characters until the desired descriptor is entered. Descriptors can be up to a maximum of 16 characters. You can use the [4] key to move the cursor to the left, if necessary. When done, press the [8] key to save the descriptor and return to the "Zone No.?" prompt. Enter the zone number for the next descriptor, press [*], and repeat steps 1-3. To change a descriptor, simply overwrite it. To exit, enter zone number "00."

CHARACTER (ASCII) CHART

032 (space)	046 = .	060 = <	074 = J	088 = X	102 = f	116 = t
033 = !	047 = /	061 = =	075 = K	089 = Y	103 = g	117 = u
034 = "	048 = 0	062 = >	076 = L	090 = Z	104 = h	118 = v
035 = #	049 = 1	063 = ?	077 = M	091 = [105 = i	119 = w
036 = \$	050 = 2	064 = @	078 = N	092 = ¥	106 = j	120 = x
037 = %	051 = 3	065 = A	079 = O	093 =]	107 = k	121 = y
038 = &	052 = 4	066 = B	080 = P	094 = ^	108 = l	122 = z
039 = '	053 = 5	067 = C	081 = Q	095 = _	109 = m	123 = {
040 = (054 = 6	068 = D	082 = R	096 = `	110 = n	124 =
041 =)	055 = 7	069 = E	083 = S	097 = a	111 = o	125 = }
042 = *	056 = 8	070 = F	084 = T	098 = b	112 = p	126 = •
043 = +	057 = 9	071 = G	085 = U	099 = c	113 = q	127 = •
044 = ,	058 = :	072 = H	086 = V	100 = d	114 = r	
045 = -	059 = ;	073 = I	087 = W	101 = e	115 = s	

Configurable Zone Type Programming (*83 Menu Mode)

Start Configurable Zone Type Programming Mode by pressing *83 while in Data Programming mode.

PROMPT	VALID ENTRIES	EXPLANATION
<div style="border: 1px solid black; padding: 5px; width: fit-content;"> Enter Zone Type (00=quit) 90 </div>	Zone Type Number 90-93 = zone type [*] to continue	Enter the configurable zone type number being programmed.
<div style="border: 1px solid black; padding: 5px; width: fit-content;"> 90 Zn Attributes 0 </div>	Zone Attributes 0 = none 1 = exit delay only 2 = entry/exit 1 3 = entry/exit 2 4 = follows entry/exit 5 = has verification (resets power upon event and when code + OFF to clear condition. If condition persists, zone activates) 6 = resettable (upon code + OFF) [*] to continue	Enter the desired zone attributes. NOTE: If 6 is selected for the Zone Attribute, enter 0 for Alarm/Trouble Processing at the below Alm/Trbl Proc prompt.
<div style="border: 1px solid black; padding: 5px; width: fit-content;"> 90 Bypass Option 0 </div>	Bypass Option 0 = zone type cannot be bypassed 1 = auto bypassed when armed in stay mode [*] to continue	Enter the desired bypass option.
<div style="border: 1px solid black; padding: 5px; width: fit-content;"> 90 Resp to Short Armed 0 DArmd 0 </div>	Response to Shorts 0=none 2=trouble 1=Alarm 3=fault [*] to continue	Select the type of response when zones assigned to this zone type are shorted when the system is armed. NOTES: 1. For double-balanced zones, this entry must be 0. 2. For zone-doubled zones, both zones of the doubled pair must be assigned the same response to a short.
<div style="border: 1px solid black; padding: 5px; width: fit-content;"> 90 Resp to open Armed 0 DArmd 0 </div>	Response to Opens 0 = none 2 = trouble 1 = Alarm 3 = fault [*] to continue	Select the type of response when zones assigned to this zone type are opened when the system is armed.
<div style="border: 1px solid black; padding: 5px; width: fit-content;"> 90 Vent Zone 0 = No, 1 = Yes </div>	Vent Zone? 0=no 1=yes [*] to continue	If selected, the system can be armed even if zones assigned to this zone type are faulted. NOTE: After arming, faults on these zones will be ignored until the zone is restored.
<div style="border: 1px solid black; padding: 5px; width: fit-content;"> 90 Alm/Trbl Proc 0 </div>	Alarm/Trouble Processing 0=none 1=Zone type has automatic restore 2=zone type uses Misc. Fault Delay Time and automatic restore [*] to continue	Select desired actions for zones assigned to this zone type. Option 2: Select Miscellaneous Fault Delay in field *87. NOTE: If 6 was selected above for the Zone Attribute, enter 0 for this prompt.

PROMPT	VALID ENTRIES	EXPLANATION
90 TRBL SOUND 0	Trouble Sounding 0= none 1= one beep every minute 2= normal trouble sound (fast beeps) [*] to continue	Select type of sounding upon trouble conditions on zones assigned to this zone type.
90 ALARM SOUND 0	Alarm Sounding 0=none 1= keypad sound only 2= steady siren sounding 3= pulsing siren (temporal) [*] to continue	Select type of sounding upon alarm conditions on zones assigned to this zone type.
90 Dial Delay 0=No, 1=Yes	Dial Delay? 0=no 1=yes [*] to continue	If selected, faults on zones assigned to this zone type will delay reporting for whatever length of time that is selected in dial delay (*50).
90 Disp Option 1	Display Options 0 = no display 1 = display only 2 = chime only 3 = chime & disp. [*] to continue	Select whether faults on zones assigned to this zone type are displayed at the keypad and/or cause a chime sound.
Alarm ID: 000 Trouble ID: 000	Contact ID Report Codes 000-999 = report code [*] to continue; returns to Enter configurable zone type number prompt.	Enter the desired 3-digit Contact ID report codes for faults and troubles occurring on zones assigned to this zone type. IMPORTANT: Make sure the code does not conflict with existing, predefined Contact ID report codes. See the <i>System Communication</i> section for a list of standard Contact ID codes.

Programming Installer and User Schedules

The system provides up to 8 schedules, which can be used to control 12 types of system events at pre-defined times. 4 schedules are intended for use by the end-user, and 4 are reserved for the installer. In addition, some events are also reserved for the installer only (listed in the “Enter Event” prompt paragraph below).

Start Scheduling mode by entering installer code + [#] + [6] [4] while in normal operating mode.

NOTE: The master code can only access schedules 01-04 and events 00-08.

The following prompts are displayed:

PROMPT	VALID ENTRIES	EXPLANATION
<div style="border: 1px solid black; padding: 5px; width: fit-content;"> ENTER SCHED NO. 00=QUIT 00 </div>	Schedule Number 01-04 = end-user schedules 05-08 = installer-only schedules [*] to continue	Enter the desired schedule number.
<div style="border: 1px solid black; padding: 5px; width: fit-content;"> ENTER EVENT </div> <div style="border: 1px solid black; padding: 5px; width: fit-content;"> NOTE: Events 07 and 10 cause the keypad to beep every 30 seconds when messages are displayed. Stop the beeps by user code + OFF. </div>	Enter Event 00 = clear event 01 = Relay On/Off 02 = User Access 03 = Child Not Home Report to Pager 04 = Auto (Forced) Stay Arm [†] 05 = Auto (Forced) Away Arm [†] 06 = Auto Disarm 07 = Display "Reminder" 08 = Disarm Time Window 11 = Periodic Test Report 12 = Up and About ^{††} [*] to continue	Enter the desired event number for event you want to occur at a specified time. Event 11 is reserved for the installer only. Child-Not-Home report (option 03) is sent to all pagers in the user's partition (message sent is 777-7777). User must be enabled for paging (see User Attributes in System Operation section). Auto Stay Arm (event 04) and Auto Arm (event 5) cannot be used if partition 3 is set as a common partition. To use these scheduling features, field *30 must be 0, making partition 3 a separate partition. Disarm Time Window (08): System can be disarmed only during this time period. Exception: If a burglary alarm occurs, the system can be disarmed outside the scheduled time window. [†] If either of these options is selected, Forced Bypass is automatically enabled regardless of setting in field *23. ^{††} This selection defines the large time window within which the time window selected in data field *85-entry 2 will be monitored.
<div style="border: 1px solid black; padding: 5px; width: fit-content;"> DEVICE NUMBER XX </div>	Device Number 01-04 = device number [*] to continue	This prompt appears if event "1" (relay on/off) was selected, otherwise it is skipped. Enter the physical device number as programmed in *79 Menu Mode, then press [*] to continue to the "Start" prompt. Device numbers 17 and 18 designate built-in triggers 1 and 2 respectively.
<div style="border: 1px solid black; padding: 5px; width: fit-content;"> GROUP NUMBER X </div>	Group Number 1-8 = group number [*] to continue	This prompt appears if event "2" (user access) was selected. Otherwise it is skipped. Press [*] to continue to the "Start" prompt.
<div style="border: 1px solid black; padding: 5px; width: fit-content;"> PARTITION X </div>	Partition 0 = all partitions 1 = partition 1 2 = partition 2 3 = common partition [*] to continue	This prompt appears if events "3-8,10" were selected. Otherwise it is skipped. Press [*] to continue to the "Start" prompt.

PROMPT	VALID ENTRIES	EXPLANATION
<pre>START SMTWTFS HH MMAM 0010000</pre>	<p>Start Time 01-12 (00-23) † = hour 00-59 = minute 0 = AM; 1 = PM (if applicable) Days = place "1" under days [*] to continue</p>	<p>Enter the event's start time and days of the week to occur. To select days, position the cursor under the desired days using the [*] key to move forward, then press "1" to select the day(s). † use 00-23 if 24-hour time is enabled.</p>
<pre>WARNING DLY TIME 00</pre>	<p>Warning Delay Time 01-15 = arm warning delay time in minutes [*] to continue</p>	<p>This prompt appears if events "4 or 5" were selected. Enter the desired amount of time the system should warn of impending arming. The system will beep once every 30 seconds to alert users that arming will soon occur. Otherwise, this prompt is skipped.</p>
<pre>STOP SMTWTFS HH MMAM 0010000</pre>	<p>Stop Time 01-12 (00-23) † = hour 00-59 = minute 0 = AM; 1 = PM (if applicable) Days = place "1" under days [*] to continue</p>	<p>Enter the event's stop time and days of the week to occur. To select days, position the cursor under the desired days using the [*] key to move forward, then press "1" to select the day(s). This entry applies only to the following events: 1 (relay on/off) 2 (user access) 3 (child-not-home report) † use 00-23 if 24-hour time is enabled.</p>
<pre>REPEAT OPTION 0-4 X</pre>	<p>Repeat Option 0 = do not repeat 1 = repeat schedule weekly 2 = repeat schedule biweekly (every other week) 3 = repeat schedule every third week 4 = repeat schedule every fourth week [*] to continue</p>	<p>Enter the desired repeat option for this schedule. e.g., To make a schedule that happens everyday you would select all days with a repeat count of 1. To make a schedule that runs for one week then stops, select everyday with a repeat count of 0. NOTE: Schedules run sequentially from Sunday to Saturday and reset on Sunday at midnight. If repeat count is 0, only those events scheduled from the day the schedule is set to Sunday will occur. Events scheduled after Sunday will be ignored.</p>
<pre>RANDOMIZE 0=NO 1=YES X</pre>	<p>Randomize 0 = no 1 = yes [*] to continue</p>	<p>If selected, the scheduled start and stop times will vary within 60 minutes of the "hour" time. For example, if a schedule is set to start at 6:15pm, it will do so the first time 6:15pm arrives, but on subsequent days it will start anytime between 6:00 and 6:59 p.m. NOTE: Do not use the random option if the start and stop times are within the same "hour" setting, otherwise unpredictable results may occur (e.g., the randomized stop time may occur before the start time).</p>

System Communication and Operation

Panel Communication with Central Station

This system accommodates several formats for reporting alarms and other system conditions to the Central Station. The process of a successful transmission consists of both the method of communication between the control panel and the Central Station receiver; and the actual way the information is sent and displayed at the Central Station.

When the panel calls the Central Station receiver, it waits to hear a “handshake” frequency from the receiver to confirm that the receiver is on-line and ready to receive its message. Once the panel hears the handshake it is programmed to listen for, it sends its message. The panel then waits for a “kissoff” frequency from the receiver acknowledging that the message was received and understood.

If the handshake frequency is not given or is not understood by the panel, the panel will not send its message. Once the handshake frequency is received and understood by the panel, the panel sends its message. If there is an error in the transmission (the receiver does not receive a “valid” message), the kissoff frequency is not given by the Central Station receiver.

The panel makes a total of eight attempts to the primary telephone number and eight attempts to the secondary telephone number (if programmed) to get a valid message through. If the panel is not successful after its numerous attempts, the keypad displays COMM. FAILURE (on alpha keypads) or FC (on fixed-word keypads).

Report Code Formats

The following chart indicates the types of (handshake/kissoff) frequencies that the panel supports and the different formats that can be sent with each.

FORMAT	HANDSHAKE	TRANSMITS DATA	KISSOFF	TRANSMIT TIME
Low Speed 3+1, 4+1, 4+2	1400 Hz	1900Hz (10PPS)	1400 Hz	Under 15 secs (Standard report)
Sescoa/Rad 3+1, 4+1, 4+2	2300 Hz	1800Hz (20PPS)	2300 Hz	Under 10 secs (Standard report)
Robofon 8	See Robofon 8 paragraph later in this section for details of the format.			
Express 4+2	1400–2300 Hz	DTMF (10 cps) (multi-frequency)	1400 Hz	Under 3 secs
ADEMCO Contact ID	1400–2300 Hz	DTMF (10 cps) (multi-frequency)	1400 Hz	Under 3 secs
Robofon Contact ID	2300 Hz	DTMF (10 cps) (multi-frequency)	1400 Hz	Under 3 secs

The following table describes each format in greater detail.

FORMAT TYPE	DESCRIPTION
3+1 and 4+1 Standard Formats	Comprises a 3- (or 4-) digit subscriber number and a single-digit report code (e.g., Alarm, Trouble, Restore, Open, Close, etc).
3+1 and 4+1 Expanded Formats	Comprises a 3- (or 4-) digit subscriber number and a two-digit report code. The first digit is displayed on the first line. On the second line, it is repeated 3 (or 4) times and is followed by the second digit. This is the "expanded" digit.
Robofon 8	Comprises a 6-digit subscriber number and a 2-digit report code.
4+2 Format	Comprises a 4-digit subscriber number and 2-digit report code.
ADEMCO and Robofon Contact ID Reporting Format	Comprises a 4-digit or 10-digit subscriber number, 1-digit event qualifier ("new" or "restore"), 3-digit event code, 2-digit partition number, and 3-digit zone number, user number, or system status number (see the following page).

The following table lists codes for reports sent in different formats:

Type of Report	Code for 3+1/4+1 Standard	Code for 3+1/4+1 Expanded	Code for 4+2/Robofon 8**
Alarm	SSS(S) A	SSS(S) A AAA(A) Z	SSSS (SS) AZ
Trouble	SSS(S) T	SSS(S) T TTT(T) t	SSSS (SS) Tt
Bypass	SSS(S) B	SSS(S) B BBB(B) b	SSSS (SS) Bb
AC Loss	SSS(S) E	SSS(S) E EEE(E) A _C	SSSS (SS) EA _C
Low Batt	SSS(S) L	SSS(S) L LLL(L) L _B	SSSS (SS) LL _B
Open	SSS(S) O	SSS(S) O OOO(O) U	SSSS (SS) OU
Close	SSS(S) C	SSS(S) C CCC(C) U	SSSS (SS) CU
Test	SSS(S) G	SSS(S) G GGG(G)g	SSSS (SS) Gg
Restore Alarm	SSS(S) R	SSS(S) R RRR(R) Z	SSSS (SS) RZ
AC Restore	SSS(S) R _A	SSS(S) R _A R _A R _A R _A (R _A)A _C	SSSS (SS) R _A A _C
LoBat Res.	SSS(S) R _L R _L R _L R _L (R _L)L _B	SSS(S) R _L	SSSS (SS) R _L L _B
Trouble Res.	SSS(S) R _T	SSS(S) R _T R _T R _T R _T (R _T)t	SSSS (SS) R _T t
Bypass Res.	SSS(S) R _B	SSS(S) R _B	SSSS (SS) R _B b

		R _B R _B R _B (R _B) ^b	
--	--	---	--

** Characters in parenthesis are included in Robofon 8 format.

Where:

- | | |
|--|--|
| SSS or SSSS = Subscriber ID | C = Close Code–1st Digit |
| A = Alarm Code–1st digit*** | U = User Number (in hex) |
| Z = Typically Zone Number*–2nd digit | Gg = Test Code (1st & 2nd digits) |
| Tt = Trouble Code (1st & 2nd digits) | R = Restore Code (Alarm) |
| Bb = Bypass Code (1st & 2nd digits) | R _{Tt} = Restore Code (Trbl) 1st & 2nd digits |
| E _A C = AC Loss Code (1st & 2nd digits) | R _{Bb} = Restore Code (Byps) 1st & 2nd digits |
| L _L B = Low Battery Code (1st & 2nd digits) | R _A A _C = Restore Code (AC) 1st & 2nd digits |
| O = Open Code–1st Digit | R _L L _B = Restore Code (Bat) 1st & 2nd digit |

- *Zone numbers for: * & #, or B = 99 Duress = 92
 1 + *, or A = 95
 3 + #, or C = 96

*** For 4+2/Robofon 8 formats, 2-digit zone numbers can be reported by assigning the A (first) digit as the first digit of the zone number, then assigning Z as the second digit of the zone number, if desired.

Robofon 8 Format

Robofon 8 format send data in a pulsed frequency format in the following protocol:

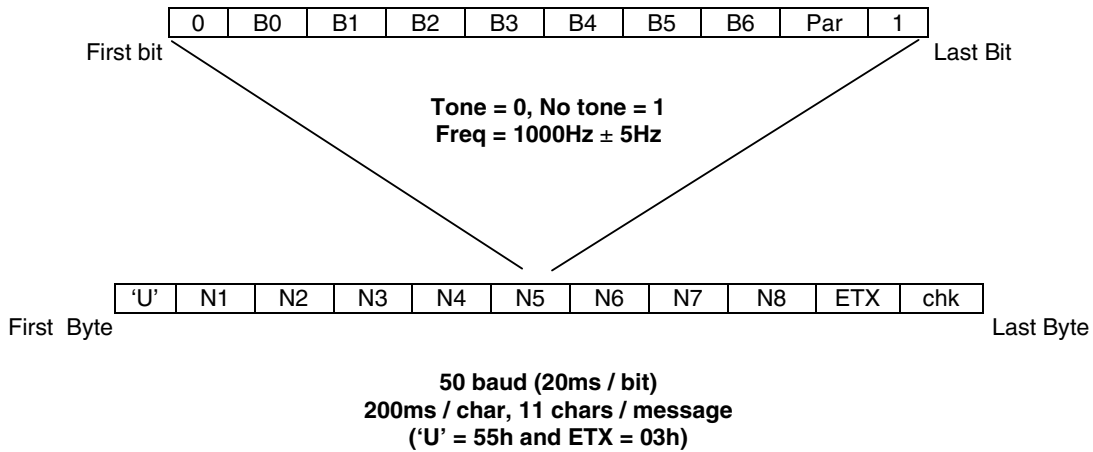

Physical format

- 1000 Hz +/- 5Hz pulsed signaling
- Tone = logical 0
- Silence = logical 1
- Speed is 50 baud, 20ms/bit, 200ms/character

Logical format

- Byte format is 7 bit data, odd parity.
- Code is always eight (8) digits, ASCII-characters 30h – 39h.
- The report format is as follows: **SSSSSS XX** where:
SSSSSS is the 6-digit account number
XX is the 2-digit report code (as in 4+2 format)

Signal flow

Receiving equipment		Dialing equipment
Send start char 'w' (77h)	←	
	←	Send message described above
Acknowledge ACK (06h)	→	
(Delay greater than 500ms)		
Send new start char 'w' (77h)	→	
	←	Send next message if available
Acknowledge ACK (06h)		
...etc		

- Dialer should start sending the message no more than 200ms after start char.
- If no response is detected the receiver retries sending start char three times (in total four) before hanging up.
- If the receiver reads a message with checksum error it will reply with NAK (15h), wait more than 500ms and then send a new start char (w).
- The receiver can optionally send a command back to the dialer after ACK. The command may be one byte with any content except 'w' (77h), ACK (06h) or NAK (15h)..

ADEMCO Contact ID®

ADEMCO and Robofon Contact ID® Reporting takes the following format:

CCCC(CCCCC) Q EEE GG ZZZ

where:

CCCC(CCCCC) =4-digit or 10-digit Customer (subscriber) ID

Q = 1-digit Event qualifier, where: E = new event , and R = restore

EEE =3-digit (hexadecimal) Event code (see central office receiver manual for a complete list of event codes)

GG = 2-digit Partition Number (system messages show "00")

ZZZ = 3-digit Zone/contact ID number reporting the alarm, or user number for open/close reports. System status messages (AC Loss, Walk Test, etc.) contain zeroes in the ZZZ location.

TABLE OF CONTACT ID EVENT CODES

Code	Definition
110	Fire Alarm
121	Duress
122	Alarm, 24-hour Silent
123	Alarm, 24-hour Audible
131	Alarm, Perimeter
132	Alarm, Interior
134	Alarm, Entry/Exit
135	Alarm, Zone Type 5
143	Alarm, Expansion Module
144	Sensor Tamper Alarm
145	ECP Module Cover Tamper Alarm
146	Silent Burglary Alarm
150	Alarm, 24-Hour Auxiliary/Monitor zone
162	Gas Alarm
301	AC Mains Power
302	Low System Battery/Battery Test Fail
305	System Reset (Log only)
309	Battery Fail
321	Siren Supervision Failure
333	Trouble, Expansion Mod. Supervision
341	Trouble, ECP Cover Tamper
344	RF Receiver Jam Detect
351	Telecom Line Fault
353	Alternative Comm. Media Trouble
354	Failure to Communicate (log only)
373	Fire Loop Trouble
374	Exit Error Alarm
380	Trouble Zone Type 5
381	RF Sensor Supervision
382	Supervision Auxiliary Wired Zone (sent after code 333 is sent)
383	RF Sensor Tamper and Double-Balanced Zone Tamper
384	RF Sensor Low-battery

Code	Definition
393	Clean Me (ESL smoke detectors only)
401	Disarmed, Armed AWAY, Armed MAXIMUM
403	Scheduled Arm/Disarm AWAY
406	Cancel by User
407	Remote Arm/Disarm (Downloading)
408	Quick Arm AWAY
409	Keyswitch Arm/Disarm AWAY
412	Successful Download/Access (see field *53 to enable code)
441	Disarmed/Armed STAY/INSTANT, Quick-Arm STAY/INSTANT
442	Keyswitch Arm/Disarm STAY
461	Wrong Code Entry (keypad lockout activated; see field *188 to enable code)
570	Bypass
601	Manually Triggered Dialer Test
602	Periodic Dialer Test
606	Audio Alarm Verification (AAV) to Follow
607	Walk Test Entered/Exited
623	Event Log 80% Full
625	Real-Time Clock was Changed (log only)
626	Time/Date Inaccurate (see field *53 to enable code)
627	Program Mode Entry (log only)
628	Program Mode Exit (log only)
641	Senior Watch Trouble (up and about)
750 - 789	Reserved for Configurable Zone Type report codes (check with central station when using these codes)
801	Override Tamper Arming (log only)
802	Override Low Battery Arming (log only)
803	Override AC Loss Arming (log only)
804	Override Supervision Arming (log only)

999	Zone Type 23 Fault (log only)
-----	-------------------------------

Security Codes

The system supports up to 16 security codes, which can each be assigned one of 5 authority levels. The authority level determines the functions each code can perform as follows:

Authority Levels (authority levels can be assigned to users 3-49 only; users 1 and 2 cannot be changed)

Level	User No.	Functions
Installer	01	perform all security functions except can disarm only if used to arm; can enter program mode; can change System Master code; cannot assign any other user codes (default = 4112)
System Master	02	only one system master code per system; can perform all security functions, add/delete users in all partitions, change system master code, view event log, set system clock, program keypad macro, program scheduled events, activate output devices (triggers/relays) (default = 1234)
Partition Master (default)	P1 = 03	Same as Master, except add/delete users limited to assigned partition only, (these users can be assigned different authority levels, if desired; any user can be assigned the partition master authority level)
0-User	03-17	perform security functions (arm, disarm, etc.) only; cannot add/delete users, view event log, set system clock or program scheduled events
1-Arm Only	see "user"	arm system only
2-Guest	see "user"	can disarm the system only if it was used to arm the system
3-Duress	see "user"	performs security functions, but also silently sends a duress message to the central station; reports as duress code user number.
4-Partition Master	see "user"	See Partition Master paragraph above; used to assign other user numbers as partition masters

Refer to the user guide for detailed procedures on adding/deleting security codes and changing user attributes.

The following is a brief description of how to add user codes.

Adding a User Code: Master code + [8] + 2-digit user no. + user's code

Deleting a User Code: Master code + [8] + 2-digit user no. + [#] [0]

Assigning Attributes: Master code + [8] + 2-digit user no. + [#] [attribute no.] + value

Attributes:	Values
1 = Authority Level	0-4 (see Authority Level table above)
2 = Access Group	0-8 (0 = not assigned to a group)
3 = Active Partition(s) for this user;	1, 2, 3 Enter partitions consecutively if more than one and press [#] to end the entries.
4 = RF Zone No.	Assigns user number to button type zone for arm/disarm (keyfob must be enrolled in system first; see Wireless Key Templates section)
5 = Open/Close Paging	1 for yes, 0 for no
6 = Open/Close Report to 1	for yes (default = yes for all users), 0 for no

Monitoring Station

SUMMARY OF ARMING MODES

Arming Mode	Features for Each Arming Mode			
	Exit Delay	Entry Delay	Perimeter Armed	Interior Armed
AWAY	Yes	Yes	Yes	Yes
STAY	Yes	Yes	Yes	No
NIGHT-STAY	Yes	Yes	Yes	only those zones listed in Night-Stay zone list
INSTANT	Yes	No	Yes	No
MAXIMUM	Yes	No	Yes	Yes

Keypad Functions

The following is a brief list of system commands. For detailed information concerning system functions, refer to the User's Manual.

Keypad Commands

Function	Description
Silence alarms	Pressing any key will silence the keypad sounder for 10 seconds. Disarming the system will silence both keypad and external sounders.
Quick Arm	If enabled (field *21), you can press [#] in place of the system's security code, plus the desired arming key (Away, Stay, Instant, Maximum)
Single-Button arming	If programmed (*57 Function Key menu mode), lettered keys A-D can be used for arming, using options 3-AWAY, 4-STAY, 5-NIGHT-STAY, or 6-Step-Arming If used, no security code is required to arm the system.
Alarm Memory	When the system is disarmed, any zones that were in an alarm condition during the armed period will be displayed. To clear this display, simply repeat the disarm sequence (enter the security code and press the OFF key) again.
Arming Away	Enter code + AWAY [2] or simply press appropriate lettered key on the keypads (see "Single-Button Arming" above). If the "Auto-Stay Arm" feature is enabled and the entry/exit door is not opened and closed within the programmed exit delay time, the system will automatically arm in STAY mode if armed from a wired keypad (non-RF device). If the door is opened and closed within the exit delay period, the system arms in AWAY mode.
Arming Stay	Enter code + STAY [3] or simply press appropriate key on the keypads (see "Single-Button Arming" above). See "Arming Away" above for Auto-Stay arming feature.
Arming Night-Stay	Enter code + STAY [3] + STAY [3] or simply press appropriate key on the keypads (see "Single-Button Arming" above).
Arming Instant	Enter code + INSTANT [7].

Installation and Setup Guide

Arming Maximum	Enter code + MAXIMUM [4] or simply press appropriate lettered key on the keypads (see “Single-Button Arming” above).
----------------	--

Keypad Commands (cont'd)

Function	Description
Disarming	Enter code + OFF [1]. If entry delay or an alarm is active, you do not need to press OFF; entering the security code alone disarms the system.
Bypassing Zones	Enter code + BYPASS [6] + zone number(s). Can bypass while system armed/disarmed.
Forced (Quick) Bypass	To automatically bypass all faulted zones, use the "Quick Bypass" method. Enter code + BYPASS + [#], then wait for all open zones to be displayed. Arm when display indicates "ZONE BYPASSED" and "READY TO ARM".
Chime Mode	Enter code + CHIME [9]. To turn chime off, enter code + CHIME again.
Activate Output Devices	If relay outputs (via a 4204, 4229, or 6164), or Powerline Carrier devices are used, two keypad entries available to the user are included. If programmed, these entries can be used to manually activate or deactivate the device(s) for starting or stopping some action, such as turning lights on or off, etc. These keypad entries are: [Security Code] + # + 7 + [2-digit Device #] activates (starts) that device. [Security Code] + # + 8 + [2-digit Device #] deactivates (stops) that device.

Panic Keys

There are three Panic keys (A, B, and C) that, if programmed, can be used to manually initiate alarms and send a report to the central station. Each key can be programmed for 24-hour Silent, 24-hour Audible, Fire, or Personal Emergency responses. The programmed Panic response is activated when the appropriate key is pressed for at least 2 seconds.

The Panic keys are identified as follows:

Keys	Displayed as Zone
[A] (*/1)	95
[B] (*/#)	99
[C] (3/#)	96

IMPORTANT: For a Silent panic function (if programmed) to be of practical value, you must program a report code for the zone and the system must be connected to a central station.

Follow-Me Feature

This feature lets users enter up to three phone numbers (system-wide) that the system will call in the event of an alarm in any partition at the protected premises, thus alerting the user to the alarm.

- When an alarm occurs, the system reports the alarm to the central station (and pagers, if programmed), then, if programmed, dials the first follow-me phone number and proceeds as follows:
 1. After dialing, the system waits a short time[†] then sends a series of eight tones or “beeps” (regardless of whether the call is answered) followed by a pause of about four seconds, then the tones are repeated. The cycle of tones and pauses continues for about one minute.
 - [†] system waits about one ring plus any programmed pauses; see “To enter a follow-me number” below for programming pauses
 2. If the call is not acknowledged by the user (by pressing the telephone’s [*] key; see **User Response** below), the control hangs up when the 1-minute tone cycle is complete, then dials the second follow-me phone number and sends the tones as described above. If the second number is not acknowledged by the user, the control dials the third number and sends the tones.
 3. If the third number is not acknowledged, the control redials the first number. This dialing cycle is repeated up to three times or until a user acknowledges the call (presses the telephone’s [*] key).
 4. **User Response:**
 - a. When the call is answered, the user will hear the message tones (a series of eight tones or “beeps”) followed by a pause of about four seconds, then the tones are repeated.
 - b. **The user must press the [*] key on the telephone** to acknowledge hearing the tones, then wait for the control to disconnect the line before hanging up.

IMPORTANT: The [*] key should be pressed during a pause between tone cycles. Otherwise, the control may not “hear” or respond to the [*] key if pressed while the tones are being sent.

 - If another alarm occurs in the same armed period, the Follow-Me dialing cycle is repeated only up to the number of reports programmed in field *93 No. of Reports in Armed Period per Zone.
 - If the follow-me number is for a pager, the message displayed on the pager is as follows: **104 P ZZZ**
where “P” is the partition number, “ZZZ” is the 3-digit zone number of the zone in alarm.

To enter a Follow-Me phone number: user code + [#] + [6] [1]

The first follow-me phone number (if it exists) is displayed:

FM Phone No. 18009216704--_

To display follow-me phone number 2, press [2].

To display follow-me phone number 3, press [3].

To modify the displayed number, do the following:

1. Press [*], which clears the number, then enter the desired phone number. To include a 2-second pause in the number, press [#] at the point in the entry the pause is desired (it displays as “-“). Pauses entered at the end of the number will allow dialing but will delay the message tones by the amount of pause programmed.
 2. Press [*] to save the new number. The next follow-me phone number in sequential order (1-2-3-1 etc.) is displayed. Press [*] to program that number, or press [1], [2], or [3] to select the desired follow-me number to be programmed.
-

Setting/Adjusting the Real-Time Clock

The real-time clock is used to time-stamp events recorded in the event log and for scheduling mode. The time display can be set for 12 (AM/PM) or 24-hour format, and can show day/month or month/day (field *183, Time/Date Format). If the system is using the built-in crystal for the real-time clock (field *181, 50/60Hz AC Operation) synchronization, a plus/minus adjustment may be required to account for crystal frequency variation. This adjustment is only needed if the frequency control of AC mains is not accurately maintained by the local mains electrical power provider.

To set and adjust the clock: user code +[#] + [6] [3].

The current setting is displayed.

Press [*] to set the time. A cursor appears under the first digit of the hour.

- Enter the 2-digit hour setting, then enter the 2-digit minute setting.
- Press [1] for PM or [0] for AM (if applicable, otherwise skip).
- Enter the last two digits of the current year.
- Enter the 2-digit month setting, then enter the 2-digit day setting.
- Press [*] to accept the settings and continue.

The Clock Adjustment prompt is displayed.

- Press [0] to add, or press [1] to subtract.
 - Enter the number of seconds per day (01-59) to add or subtract to keep the real-time clock accurate.
 - Press [*] to accept the setting and exit.
-

Various System Trouble Displays

Alpha Display	Fixed Disp.	Meaning
CANCELED ALARM	CA	Appears if an exit or interior zone contained a fault during closing at the time the Exit Delay ended (e.g., exit door left open and the zone was not auto-bypassed), but the system was disarmed during the Entry Delay time. The alarm sounder and keypad sounder stop when the system is disarmed. No message will be transmitted to the central station.
EXIT ALARM	EA	will appear when the Exit Delay ends if an exit or interior zone contained a fault during closing and the zone was not auto-bypassed. The alarm sounder and keypad sound continuously until the system is disarmed (or timeout occurs). An "Exit Alarm" message is sent to the central station if enabled in field *59. Also results if an alarm from an exit or interior zone occurs within 2 minutes after the end of an Exit Delay if exit alarm is enabled in field *59.
CHECK	CHECK	indicates that a problem exists with the displayed zone(s) and requires attention.
ALARM 1xx FAULT 1xx CHECK 1xx	1xx 1xx 1xx 91	indicates that communication between control and a zone expander or wireless receiver is interrupted, where "xx" is the device address. Check the wiring and DIP switch settings on the units. If field *199 is set to "1," all ECP module problems are displayed as "91." If there are wireless sensors in the system, the Check condition may also be caused by some change in the environment that prevents the receiver from receiving signals from a particular sensor.
TAMPER 1xx	1xx	Appears when a tamper switch at the device address shown has been activated while system is disarmed.
TMPR_ARMD	1xx	Appears when a tamper switch at the device address shown has been activated while system is armed.
SYSTEM LO BAT	BAT	with no zone number indicates that the system's main standby battery is weak.
LO BAT	BAT	with a zone number and a once-per-minute beeping at the keypad indicates that a low-battery condition exists in the wireless sensor displayed (zone "00" indicates a wireless keypad). If the battery is not replaced within 30 days, a "CHECK" display may occur. Note: Some wireless sensors contain a non-replaceable long-life battery which requires replacement of the entire unit at the end of battery life (e.g., 5802 and 5802CP).
TELECOM FAULT	94	Telephone Line Failure, indicates that a monitored telephone line (if programmed in field *92) has been cut or disconnected. Depending on how the system was programmed, the keypad may also produce a trouble sound, and the external sounder may be activated. Silence by entering installer code + OFF.

Various System Trouble Displays (cont'd)

Busy-Standby	dI	If this remains displayed for more than 1 minute, the system is disabled.
Modem Comm	CC	The system is in communication with the central station for change of function or status verification.
no display	no display	<p>Power Failure If there is no keypad display at all and the LEDs are unlit, operating power (AC and battery) for the system has stopped and the system is inoperative. If the message "AC LOSS" (Alpha display keypads) or "NO AC" (Fixed-Word display keypads) is displayed, the keypad is operating on battery power only. If the battery standby capacity is used up during a prolonged AC power outage, the control's power will shut down to minimize deep discharge of the battery. The display may also be blanked intentionally (except during exit delay and for 30 seconds after disarming, or during a mains power loss) if field *186 Display Options entry 2 is enabled.</p>
Comm. Failure	FC	A communication failure has occurred.
Open Circuit	OC	The keypad is not receiving signals from the control and sees an open circuit.
Long Rng Trbl	bF	Backup Alternative Communication Media communication failure.
Bell Failure	70	Siren supervision failure.
RCVR Jam	90	RF jam detected.
KEYPAD LOW BAT	00 BAT	Wireless keypad low battery
Phone Okay	Cd	The dialer test has been successful (CID code 601).
Dialer Off	dO	The dialer is disabled.
Test in Progress	dd	Walk test mode is active(CID code 607).
Upload Completed	dC	The upload or download session was completed.

Upload Failed dF The upload or download session failed before completion.

SECTION 7

Testing the System

.....

About Test Procedures

After the installation is complete, you should perform the following tests:

System Test: Checks that all zones have been installed properly.

Dialer Test: Checks that the phone connection to the central station is working properly.

Go/No Go Test: Checks that transmissions can be received from transmitters. Should be performed before permanently mounting transmitters.

Sensor Sniffer Mode: Allows one-man walk test of entire system.

Battery Tests: Automatic battery tests are performed by the system. See Automatic Battery Test paragraph for details.

System Test

With the system in the disarmed state, check that all zones are intact (not faulted). Doors and windows with contacts should be closed, PIRs should be covered (use a cloth to mask them temporarily if necessary). If a “NOT READY” message is displayed, press [*] to display the faulted zone(s). Restore faulted zone(s) if necessary, so that the “READY” message is displayed.

1. Enter Installer Code + 5 [TEST], then press “0” at the prompt to start Walk Test mode.

1=DIAL, 0=WALK

(no special display on Fixed-Word keypads)

The following will be displayed:

TEST IN PROGRESS

(“dd” displayed on Fixed-Word Display Keypads)

A Contact ID report will also be sent (code 607)

2. Upon entering the system test mode, the outside sounder should sound for 1 second. If the backup battery is discharged or missing, the sounder may not turn on and a “LOW BATTERY” report will be transmitted with a “TEST” report. The keypad will beep once per minute as a reminder that the system is in the Test mode.
NOTE: Wireless motion detectors (Passive Infrared units) will send signals out only if they have been inactive for 3 minutes from their prior transmission (conserves battery life).
3. Test all sensors using the procedure described in the User’s Guide “Testing the System” section.
4. After checking sensors, turn off the test mode by entering installer code + OFF.

NOTE: Test mode automatically ends after 4 hours. During the final 5 minutes (after 3 hours 55 minutes of Test mode), the keypad emits a double-beep every 30 seconds to alert that the end of Test mode is nearing.

Checking Zones Using One-Man Walk Test (Sniffer Mode)

Use this mode to test all zones (wired and wireless) that have been programmed. Make sure all partitions are disarmed before trying to enter this mode, since this is a system-wide command.

1. Press [Installer code] + [#] + 3.

NOTE: If the communicator is in the process of sending a report to the central station, the system will not go into the Sniffer mode. If so, wait a few minutes, and try again.

The keypads in all partitions will display all zone numbers (in all partitions) programmed in the system. Fault each zone in turn, causing each one to send a signal. As the system receives a signal from each of the zones, the corresponding zone number disappears from the display.

2. After all zones have been checked, exit the Sniffer Mode by keying [Installer code] + OFF.

IMPORTANT: Sniffer mode does not automatically expire. You must manually exit Sniffer Mode (by entering [Installer code] + OFF) to return to normal operation.

NOTES:

- All BR type RF units (e.g., 5804) must physically be activated to clear the display.
- When **one** button of a transmitter (RF, UR, or BR) is activated, all zones assigned to other buttons on that transmitter are cleared. This also applies to multiple-loop transmitters (e.g., 5816 and 5817).
- Any transmitter not “enrolled” or any zone that is not faulted will not turn off its zone number.

Go/No Go Test Mode

The Go/No Go Test verifies adequate RF signal strength from the proposed transmitter location, and allows you to reorient or relocate transmitters if necessary, before mounting the transmitters permanently. This mode is similar to the Transmitter Test mode, except that the wireless receiver gain is reduced. This will enable you to make sure that the RF signal from each transmitter is received with sufficient signal power when the system is in the normal operating mode.

1. Enter [Installer code] + [#] + 4 from the partition being tested. Repeat this test for each partition.
2. After you have placed transmitters in their desired locations and the approximate length of wire to be run to sensors is connected to the transmitter's screw terminals (if used), fault each transmitter.
3. Do not conduct this test with your hand wrapped around the transmitter.
 - a. Keypad beeps three times to indicate signal reception and displays the appropriate zone number.
 - b. If the keypad does not beep, you should reorient or move the transmitter to another location. Usually a few centimeters in either direction is all that is required.
4. If each transmitter produces the proper keypad response when it is faulted, you can then permanently mount each of the transmitters according to the instructions provided with them.
5. Exit the Go/No Go Test mode by entering: [Installer code] + OFF.

Dialer Communication Test

1. Enter Installer Code + 5 [TEST], then press “1” at the prompt to start the Dialer Test.

1=DIAL, 0=WALK

(no special display on Fixed-Word keypads)

The following will be displayed (accompanied by 2 beeps) if test is successful:

PHONE OKAY

(“Cd” displayed on Fixed-Word Display Keypads)

A Contact ID report will also be sent (code 601)

If the dialer test is unsuccessful, the following is displayed:

COMM FAILURE

(“FC” displayed on Fixed-Word Display Keypads)

2. Enter installer code + OFF to clear the display and exit.

Automatic Standby Battery Tests

1. An automatic test is conducted every 3 minutes to ensure that a standby battery is present and properly connected. If a battery is not present or is not properly connected, a “LOW BATTERY” message is displayed and, if so programmed, will be reported to the central station.
 2. A battery capacity test is automatically conducted for 2 minutes every 4 hours, beginning 4 hours after exiting the Programming mode or after powering up the system. In addition, entry into the Test mode will also cause a battery capacity test to be initiated. If the battery cannot sustain a load, a “Low Battery” message is displayed and, if so programmed, will be reported to the central station.
-

Specifications & Accessories

.....

SECURITY CONTROL

1. **Physical:** 318mm x 368mm x 76mm
2. **Electrical:**
 - VOLTAGE INPUT: 16.5VAC from plug-in 25VA minimum transformer
 - RECHARGEABLE BACKUP BATTERY: 12VDC, 4AH minimum (sealed lead acid type).
 - Charging Voltage: 13.8VDC.
 - ALARM SOUNDER: 12V, 2.0 Amp output can drive 12V sirens or can drive one or two 702 (series) self-contained 20-watt sirens. Do **not** connect two 702s in parallel.
 - AUXILIARY POWER OUTPUT: 12VDC, 600mA max.
 - FUSE: Battery (3A) No. 90-12
3. **Communication:**
 - FORMAT SUPPORTED:
 - ADEMCO Express: 10 characters/sec, DTMF (multi-frequency) Data Tones, 1400/2300Hz ACK, 1400Hz KISSOFF.
 - ADEMCO Low Speed: 10 pulses/sec, 1900Hz Data Tone, 1400Hz ACK/KISSOFF.
 - Radionics/SESCOA: 20 pulses/sec, 1800Hz Data Tone, 2300Hz ACK/KISSOFF.
 - Can report 0-9, B-F
 - Robofon 8 See description in Communication section.
 - ADEMCO Contact ID 10 characters/sec., DTMF (multi-frequency) Data Tones, 1400/2300Hz ACK, 1400Hz KISSOFF.
 - Robofon Contact ID same as ADEMCO except 2300Hz ACK
 - LINE SEIZE: Double Pole
 - DOC Load No.: 3
4. **Maximum Zone Resistance:** Zones 1-8 = 300 ohms excluding EOLR in standard EOLR zones

COMPATIBLE DEVICES

Keypads:	6128RF, 6148, 6150, 6150RF, 6150V, 6160V, 6164
Wireless Receivers:	5881ENL: accepts up to 8 transmitters 5881ENM: accepts up to 16 transmitters 5881ENH: accepts up to system maximum transmitters 5883M: accepts up to 16 transmitters 5883H: accepts up to system maximum transmitters 6128RF: accepts up to 16 transmitters plus 8 wireless keys 6150RF: accepts up to 16 transmitters 5800TM Transmitter Module (used with 5827BD Wireless 2-Way Keypad)
Zone Expansion:	4219 WIRED EXPANSION MODULE 4229 WIRED EXPANSION/RELAY MODULE 6164 KEYPAD w/WIRED EXPANSION and RELAY
Relay Module: Internet/Intranet Communicator:	4204 RELAY MODULE 7845i
EUREKA Network Interface:	AI4164RS (RS484 LAN)/AI4164ETH (ETHERNET LAN/WAN)
Transformers:	VISTA-12A: XF1 Model 60844CK, Ap11 V/99090/E148-36 VISTA-12E: 16.5VAC, 25VA wired-in transformer
Sounders:	ADEMCO AB-12M 25cm Motorized Bell & Box ADEMCO 1011BE12M 25cm Motorized Bell & Box ADEMCO 702 Outdoor Siren ADEMCO 719 2-Channel Siren ADEMCO 747 Indoor Siren ADEMCO 744 Siren Driver ADEMCO 745X3 Voice Siren Driver ADEMCO 705-820, 12.5cm Round Speaker ADEMCO 713 Speaker System Sensor PA400B (beige)/; PA400R (red) Indoor Piezo Sounder

5800 Series Transmitter Input Loop Identification

All of the transmitters illustrated below have one or more unique factory assigned input (loop) ID codes. Each of the input loops requires its own programming zone (e.g., a 5804's four inputs require four programming zones).

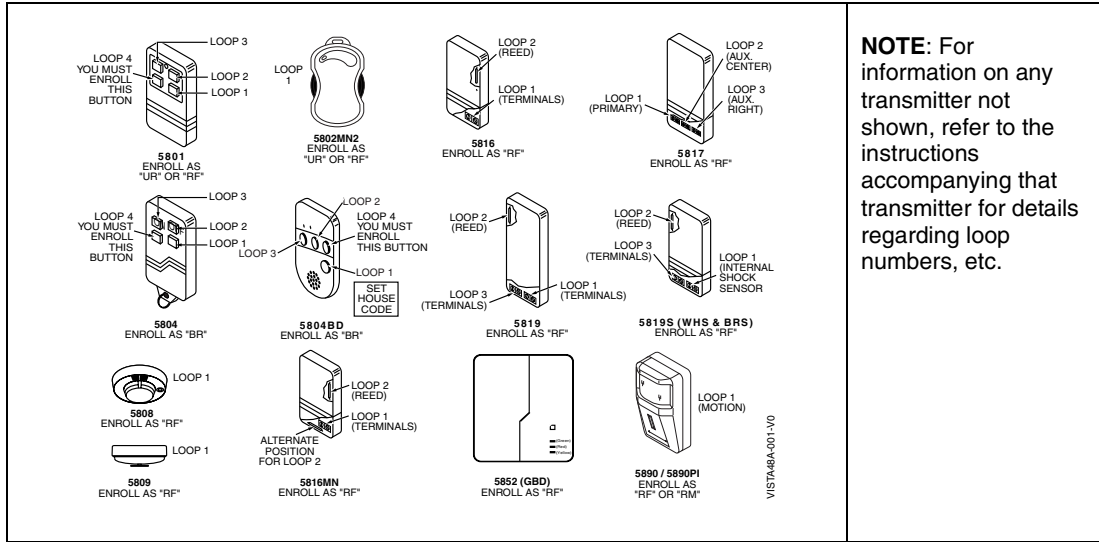

Compatible 5800 Series Transmitters Table

Model	Product	Input Type	Description
5801	Wireless Panic Transmitter	UR or RF	<ul style="list-style-type: none"> Four pushbuttons, each with a unique input (loop) code. Programmable responses (e.g., Panic, Arm, Disarm, etc.)
5802	Pendant (Personal Emergency Transmitter)	BR Only	<ul style="list-style-type: none"> Has single pushbutton. Usually programmed for response type of 24-Hr audible or 24-Hr Silent (other zone responses are possible).
5802CP	Belt Clip (Personal Emergency)	BR Only	Same as 5802.
5802MN 5802MN2	Miniature (Personal Emergency Trans.)	UR or RF	Same as 5802.
5804	Wireless Key Transmitter	BR Only	<ul style="list-style-type: none"> Has four pushbuttons, each with a unique input (loop) code. Programmable responses (e.g., Arm, Disarm, etc.)

Compatible 5800 Series Transmitters Table (cont'd)

Model	Product	Input Type	Description
5804BD	Bi-Directional Wireless Key	BR Only	<ul style="list-style-type: none"> • House ID must be set. • Requires 5800TM Transmitter Module or 5883 Transceiver. • Can indicate system status via its 2 LEDs and built-in sounder. • Has four pushbuttons, each with a unique input (loop) code. • Operates the system similarly to wired keypads.
5806 5807 5808LST	Wireless Photoelectric Smoke Detectors	RF	One-piece smoke detectors with a built-in transmitter.
5809	Heat Detector	RF	One-piece rate-of-rise heat detector with a built-in transmitter.
5816 5816MN	Door/Window Transmitters	RF	Has two unique input (loop) codes: one for a wired closed circuit contact loop; the other for its built-in reed switch (used with a magnet).
5816TEMP	Low-Temp. Sensor	RF	Transmits a fault condition when temperature drops below 45°F.
5817	Multi-Point Universal Transmitter	RF	Has three unique input (loop) codes: one for a "Primary" contact loop with programmable options; the others for two "auxiliary" closed circuit contact loops.
5818	Recessed Transmitter	RF	<ul style="list-style-type: none"> • Reed switch magnetic contact sensor; easily hidden in the frame and edge of a door or window. • Has a single unique input (loop) code.
5819	Shock Processor Transmitter	RF	<ul style="list-style-type: none"> • Connects to externally mounted inertia-type shock detector (not supplied). • Has built-in tampered cover switch. • Has 3 unique input (loop) codes: <ul style="list-style-type: none"> <i>Loop 1:</i> Terminals for a wired, N.C. sensor loop. <i>Loop 2:</i> For a closed circuit contact loop using the built-in reed switch in conjunction with a magnet. <i>Loop 3:</i> Terminals for a wired, closed circuit contact loop.

Compatible 5800 Series Transmitters Table (cont'd)

Model	Product	Input Type	Description
5819WHS 5819BRS	Shock Processor Transmitter	RF	<ul style="list-style-type: none"> • Has built-in shock sensor. • Has built-in tampered cover switch. • Has 3 unique input (loop) codes: <ul style="list-style-type: none"> <i>Loop 1:</i> Built-in shock sensor loop wired to TB1 (normally closed). <i>Loop 2:</i> For a closed circuit contact loop using the built-in reed switch in conjunction with a magnet. <i>Loop 3:</i> Externally wired, closed circuit loop connected to TB2.
5827	Wireless Keypad	Uses House ID only	<ul style="list-style-type: none"> • Can be used to turn the burglary protection on and off. • Features the same built-in panic functions as wired keypads. • The keypad is identified as zone "00" on wired keypads when it transmits with a low battery.
5827BD	Wireless Two-Way Keypad	Uses House ID only	<ul style="list-style-type: none"> • Requires 5800TM Transmitter Module. • Operates the system similarly to wired keypads, including panics. • Can indicate system status via its 3 LEDs and sounder. • Includes 3 panic keys.
5849 5852	Glassbreak Detector	RF	<ul style="list-style-type: none"> • House ID must also be set. • 5849 requires both sound and shock of breaking glass to cause alarm to be transmitted. • 5852 uses intelligent acoustic processing.
5890 5890PI	PR Detector	RF or RM	<p>Dual-element passive infrared detector/transmitter with built-in selectable pulse count.</p> <p><i>Note:</i> There is a 3-minute lockout between fault transmissions to conserve battery life.</p>
5899	Magnets		Package of 4 magnets for use with 5816, 5817, and 5819WHS transmitters.

Limitations and Warranty



WARNING

THE LIMITATIONS OF THIS ALARM SYSTEM

While this System is an advanced design security system, it does not offer guaranteed protection against burglary, fire or other emergency. Any alarm system, whether commercial or residential, is subject to compromise or failure to warn for a variety of reasons. For example:

- Intruders may gain access through unprotected openings or have the technical sophistication to bypass an alarm sensor or disconnect an alarm warning device.
- Intrusion detectors (e.g., passive infrared detectors), smoke detectors, and many other sensing devices will not work without power. Battery-operated devices will not work without batteries, with dead batteries, or if the batteries are not put in properly. Devices powered solely by AC will not work if their AC power supply is cut off for any reason, however briefly.
- Signals sent by wireless transmitters may be blocked or reflected by metal before they reach the alarm receiver. Even if the signal path has been recently checked during a weekly test, blockage can occur if a metal object is moved into the path.
- A user may not be able to reach a panic or emergency button quickly enough.
- While smoke detectors have played a key role in reducing residential fire deaths, they may not activate or provide early warning for a variety of reasons in as many as 35% of all fires. Some of the reasons smoke detectors used in conjunction with this System may not work are as follows. Smoke detectors may have been improperly installed and positioned. Smoke detectors may not sense fires that start where smoke cannot reach the detectors, such as in chimneys, in walls, or roofs, or on the other side of closed doors. Smoke detectors also may not sense a fire on another level of a residence or building. A second floor detector, for example, may not sense a first floor or basement fire. Finally, smoke detectors have sensing limitations. No smoke detector can sense every kind of fire every time. In general, detectors may not always warn about fires caused by carelessness and safety hazards like smoking in bed, violent explosions, escaping gas, improper storage of flammable materials, overloaded electrical circuits, children playing with matches, or arson. Depending on the nature of the fire and/or location of the smoke detectors, the detector, even if it operates as anticipated, may not provide sufficient warning to allow all occupants to escape in time to prevent injury or death.
- Passive Infrared Motion Detectors can only detect intrusion within the designed ranges as diagrammed in their installation manual. Passive Infrared Detectors do not provide volumetric area protection. They do create multiple beams of protection, and intrusion can only be detected in unobstructed areas covered by those beams. They cannot detect motion or intrusion that takes place behind walls, ceilings, floors, closed doors, glass partitions, glass doors, or windows. Mechanical tampering, masking, painting or spraying of any material on the mirrors, windows or any part of the optical system can reduce their detection ability. Passive Infrared Detectors sense changes in temperature; however, as the ambient temperature of the protected area approaches the temperature range of 32° to 40°C, the detection performance can decrease.

Installation and Setup Guide

- Alarm warning devices such as sirens, bells or horns may not alert people or wake up sleepers if they are located on the other side of closed or partly open doors. If warning devices are located on a different level of the residence from the bedrooms, then they are less likely to waken or alert people inside the bedrooms. Even persons who are awake may not hear the warning if the alarm is muffled by noise from a stereo, radio, air conditioner or other appliance, or by passing traffic. Finally, alarm warning devices, however loud, may not warn hearing-impaired people.
- Telephone lines needed to transmit alarm signals from a premises to a central monitoring station may be out of service or temporarily out of service. Telephone lines are also subject to compromise by sophisticated intruders.
- Even if the system responds to the emergency as intended, however, occupants may have insufficient time to protect themselves from the emergency situation. In the case of a monitored alarm system, authorities may not respond appropriately.
- This equipment, like other electrical devices, is subject to component failure. Even though this equipment is designed to last as long as 10 years, the electronic components could fail at any time.

The most common cause of an alarm system not functioning when an intrusion or fire occurs is inadequate maintenance. This alarm system should be tested weekly to make sure all sensors and transmitters are working properly. The security keypad (and remote keypad) should be tested as well.

Wireless transmitters (used in some systems) are designed to provide long battery life under normal operating conditions. Longevity of batteries may be as much as 4 to 7 years, depending on the environment, usage, and the specific wireless device being used. External factors such as humidity, high or low temperatures, as well as large swings in temperature, may all reduce the actual battery life in a given installation. This wireless system, however, can identify a true low-battery situation, thus allowing time to arrange a change of battery to maintain protection for that given point within the system.

Installing an alarm system may make the owner eligible for a lower insurance rate, but an alarm system is not a substitute for insurance. Homeowners, property owners and renters should continue to act prudently in protecting themselves and continue to insure their lives and property.

We continue to develop new and improved protection devices. Users of alarm systems owe it to themselves and their loved ones to learn about these developments.

LIMITED WARRANTY

Honeywell International Inc., acting through its Security & Custom Electronics business ("Seller") 165 Eileen Way, Syosset, New York 11791, warrants its product(s) to be in conformance with its own plans and specifications and to be free from defects in materials and workmanship under normal use and service for 24 months from the date stamp control on the product(s) or, for product(s) not having a manufacturer's date stamp, for 12 months from date of original purchase unless the installation instructions or catalog sets forth a shorter period, in which case the shorter period shall apply. Seller's obligation shall be limited to repairing or replacing, at its option, free of charge for materials or labor, any product(s) which is proved not in compliance with Seller's specifications or proves defective in materials or workmanship under normal use and service. Seller shall have no obligation under this Limited Warranty or otherwise if the product(s) is altered or improperly repaired or serviced by anyone other than Honeywell factory service. For warranty service, return product(s) transportation prepaid, to Honeywell Factory Service, 165 Eileen Way, Syosset, New York 11791.

THERE ARE NO WARRANTIES, EXPRESS OR IMPLIED, OF MERCHANTABILITY, OR FITNESS FOR A PARTICULAR PURPOSE OR OTHERWISE, WHICH EXTEND BEYOND THE DESCRIPTION ON THE FACE HEREOF. IN NO CASE SHALL SELLER BE LIABLE TO ANYONE FOR ANY CONSEQUENTIAL OR INCIDENTAL DAMAGES FOR BREACH OF THIS OR ANY OTHER WARRANTY, EXPRESS OR IMPLIED, OR UPON ANY OTHER BASIS OF LIABILITY WHATSOEVER, EVEN IF THE LOSS OR DAMAGE IS CAUSED BY THE SELLER'S OWN NEGLIGENCE OR FAULT.

Seller does not represent that the product(s) it sells may not be compromised or circumvented; that the product(s) will prevent any personal injury or property loss by burglary, robbery, fire or otherwise; or that the product(s) will in all cases provide adequate warning or protection. Customer understands that a properly installed and maintained alarm system may only reduce the risk of a burglary, robbery, fire, or other events occurring without providing an alarm, but it is not insurance or a guarantee that such will not occur or that there will be no personal injury or property loss as a result. CONSEQUENTLY, SELLER SHALL HAVE NO LIABILITY FOR ANY PERSONAL INJURY, PROPERTY DAMAGE OR OTHER LOSS BASED ON A CLAIM THAT THE PRODUCT(S) FAILED TO GIVE WARNING. HOWEVER, IF SELLER IS HELD LIABLE, WHETHER DIRECTLY OR INDIRECTLY, FOR ANY LOSS OR DAMAGE ARISING UNDER THIS LIMITED WARRANTY OR OTHERWISE, REGARDLESS OF CAUSE OR ORIGIN, SELLER'S MAXIMUM LIABILITY SHALL NOT IN ANY CASE EXCEED THE PURCHASE PRICE OF THE PRODUCT(S), WHICH SHALL BE THE COMPLETE AND EXCLUSIVE REMEDY AGAINST SELLER.

This warranty replaces any previous warranties and is the only warranty made by Seller on this product(s). No increase or alteration, written or verbal, of the obligations of this Limited Warranty is authorized.

SECTION 10

Index

<p>13212-5</p> <p>1321X10..... 2-16, 2-17</p> <p>24-Hour Audible Alarm3-6</p> <p>24-Hour Auxiliary Alarm.....3-6</p> <p>24-Hour Silent Alarm3-6</p> <p>3+1 and 4+1 Standard Formats6-2</p> <p>4204.1-2, 1-3, 2-7, 2-9, 2-15, 3-1, 5-12, 5-13, 6-8, 8-2</p> <p>4219..1-1, 1-2, 1-3, 2-7, 2-10, 8-2</p> <p>4229.1-1, 1-2, 1-3, 2-7, 2-9, 2-10, 2-11, 2-15, 3-1, 5-12, 5-13, 6-8, 8-2</p> <p>4-Wire Smoke Detectors..... 2-9</p> <p>5137AD2-3, 3-9</p> <p>5800 Series Transmitters ... 2-13, 8-3, 8-4,</p> <p>5800TM.....2-13, 8-2, 8-4, 8-5</p> <p>58012-13, 8-3</p> <p>58022-13, 6-11, 8-3</p> <p>5802CP2-13, 6-11, 8-3</p> <p>5804 wireless key5-8</p> <p>5804BD wireless key5-8</p> <p>58272-13, 4-2, 8-5</p> <p>5827BD2-13, 4-2, 8-2, 8-5</p> <p>58811-2</p> <p>61282-3</p> <p>61392-3, 3-9</p> <p>9-pin connector.....2-14</p> <p>AAV Connections2-19</p> <p>AC Transformer.....2-5</p> <p>AD126122-3</p> <p>Alarm Bell Timeout4-3</p> <p>Alarm Output1-2, 2-5</p> <p>Alarm Sounder Timeout.....4-3</p> <p>Alpha Descriptor.....5-1, 5-5</p> <p>Alpha Keypads3-9</p> <p>Alpha Programming.....3-1</p> <p>Arm Away/Stay Report Code4-8</p> <p>Arm-Away3-7</p> <p>Arming Away6-7</p> <p>Arming Instant6-7</p> <p>Arming Modes6-7</p> <p>Arming Stay6-7</p> <p>Arm-Stay3-7</p> <p>Audio Alarm Verification 1-2, 2-18, 4-12</p>	<p>Audio Alarm Verification (AAV) 2-18</p> <p>Authority Levels 6-6</p> <p>Backup Battery 1-2</p> <p>Battery Life 2-13</p> <p>Battery Tests 7-1, 7-3</p> <p>Bell Supervision..... 2-5</p> <p>Bell Supervision Jumper 2-5</p> <p>Bypassing Zones 6-8</p> <p>Cabinet2-1</p> <p>Character List 5-21</p> <p>Charging Voltage..... 8-1</p> <p>Chime By Zone 4-2</p> <p>Chime Mode 6-8</p> <p>common zone 3-2</p> <p>Communication... 5-20, 6-1, 7-3, 8-1</p> <p>Contact ID Reporting 8-1</p> <p>Data Field Programming Procedures 3-9</p> <p>Defining Output Functions .. 5-14</p> <p>Descriptor Programming 5-20</p> <p>device address .. 2-3, 2-11, 2-15, 3-1, 3-11, 4-2, 4-20, 5-12, 6-11</p> <p>Device number5-1, 5-2, 5-3, 5-4, 5-5, 5-6, 5-7, 5-8, 5-9, 5-10, 5-13, 5-14, 5-15, 5-16, 5-17, 5-18, 5-19, 5-20, 5-24</p> <p>DIP Switches. 2-13</p> <p>Disarm 3-7</p> <p>Disarming 5-16, 6-7, 6-8</p> <p>Double-Balanced 2-8</p> <p>Enrolling 2-13, 5-1</p> <p>entering serial number 5-7</p> <p>Entry Delay.... 3-6, 4-8, 6-7, 6-11</p> <p>Entry Delay 02 4-3</p> <p>Entry/Exit Burglary..... 3-5</p> <p>EOLR 2-8, 8-1</p> <p>Event Logging..... 1-1, 4-11</p> <p>Exit Error Alarm 6-5</p> <p>Exit Error Alarm 6-11</p> <p>Exit Error Report Code 4-8</p> <p>Expander Module Addresses..... 2-10, 2-11</p> <p>Expansion Zones1-3, 2-10, 2-11, 2-15</p> <p>Expert Programming Mode..... 5-1, 5-6, 5-10</p>	<p>Factory Defaults3-10</p> <p>Fault Delay Time4-11</p> <p>Fire Sounder Timeout.....4-3</p> <p>Forced Bypass Function.....4-1</p> <p>Function Key Programming..1-3, 3-1, 5-18, 5-19</p> <p>Function Keys3-4, 5-19</p> <p>Fuse.....8-1</p> <p>Go/No Go Test Mode7-2</p> <p>Handshake.....6-1</p> <p>hardwired zones..... 1-1, 5-3</p> <p>HAYES Modem.....1-1</p> <p>House ID..... 2-13, 4-2, 8-4, 8-5</p> <p>IBM Personal Computer.....3-1</p> <p>Input Device Type.. 5-7, 8-3, 8-4, 8-5</p> <p>Installer Code. 3-10, 4-1, 7-1, 7-3</p> <p>Interior Follower3-5, 5-16</p> <p>Interior w/Delay3-6, 5-16</p> <p>keypad addresses..... 2-3, 3-3</p> <p>Keypad Programming Fields.....4-19</p> <p>Keyswitch..... 2-14, 3-7, 6-5</p> <p>Kissoff.....5-16, 6-1</p> <p>Lock.....2-1</p> <p>Long Range Radio 1-2, 2-18, 4-6, 4-7, 6-5</p> <p>Low Battery Message.....7-3</p> <p>macros.....1-1</p> <p>Master Security Code.....4-1</p> <p>model 1122-14</p> <p>Modem.....3-1, 6-12</p> <p>Module Addresses5-13</p> <p>momentary switch2-14</p> <p>No Alarm Response.....3-7, 5-16</p> <p>Normally Closed Zones.....2-8</p> <p>Normally Open Zones2-8</p> <p>on-board triggers.....2-19</p> <p>On-Board Triggers2-17</p> <p>Output Device Mapping.3-1, 5-12</p> <p>Output Devices 3-4, 5-12, 6-8</p> <p>Output Functions.....5-12</p> <p>Output relays1-2</p> <p>Output To Long Range Radio.....4-2</p> <p>PABX Access Code4-4</p> <p>Pager #1 Phone No....4-13, 4-14</p> <p>Pager Format4-14</p> <p>Pager Programming3-4, 4-13</p>
--	---	---

Installation and Setup Guide

Pager Programming Fields ..4-13	Reports In Armed Period..... 4-12	System Status Report Codes.4-7
Pager Report Options4-14	response time 2-10, 4-11, 5-2	System Test7-1
Paging4-12	RF House ID Code..... 3-3, 4-2	tamper switch.....2-14
Panic Keys.....6-8	RF Interference 2-12	Telco Line6-5
Partitions.....3-2	RF jam detection..... 1-1	Telephone Line Monitoring.....1-1
Perimeter Burglary3-5	RF Jam Option..... 3-3	Test Mode..... 7-1, 7-2
Phone Line2-18	RF Motion 5-3	touchpads4-8
Phone Module.....1-1, 2-4, 2-7, 2-19, 4-13	RF Receiver... 2-4, 2-7, 2-12, 6-5	Transmitter Battery Life.....2-13
Power Failure5-16, 6-12	Ring Detection Count For	Transmitter Input Types5-3
power supply2-3, 2-5, 9-1	Downloading 4-13	Trouble by Day/.....3-5
Power Up In Previous State...4-4	RJ31X Jack..... 2-18	Trouble Displays6-11
Powerline Carrier Device (X-10)	Schedules 5-23	Verify Operation2-9
House ID4-2	Secondary Phone No.4-5	Wireless Key Programming
Powerline Carrier	Security Codes..... 1-1, 6-6	Templates.....5-8
Devices1-2, 2-16, 6-8	Silent Burglary..... 3-7, 5-16, 6-5	wireless key templates5-8
Primary Phone No.4-7	Silent Panic..... 6-8	Wiring Length/Gauge Chart...2-3
Primary Phone No.4-4	Single Alarm Sounding	Wiring Run Chart 2-3, 2-4
prompt to confirm5-8	Per Zone 4-3	Worksheet.....2-7
Quick Arm Enable3-3	Smoke Detectors 8-4	Zone Doubling2-8
Relay Module Addresses.....2-15	Sniffer Mode 5-5, 7-1, 7-2	Zone List3-1
Relay Modules.....1-3, 2-15	sounder connections 2-5	Zone Lists3-1, 5-17, 5-18
Relay Programming.....3-1	Supervised Fire..... 3-6	Zone Not Used.....3-5
Remote Keypads.....1-2	Supplementary Power..... 2-3	Zone Programming5-1
Report Code ..3-3, 4-8, 4-9, 4-11, 5-2, 5-3, 5-7, 6-1	Swinger Suppression 4-12	Zone Programming
Report Code Formats6-1	System Communication . 5-2, 6-1	Procedure..... 5-1
	System Operation 4-1, 5-8, 5-10, 5-16, 5-24	Zone Type.....5-7
		Zone Types.... 2-8, 3-5, 5-2, 5-16

BATTERY CAPACITY FOR EMERGENCY USE AT LEAST 4 HRS
 3A FOR REPLACEMENT. USE SAME VALUE (E.G. ADEMCO No. 10-2)

BATTERY
 12V, 6AH
 CHARGING VOLTAGE 13.8VDC MAXIMUM
 CHARGING CURRENT 650mA

FLYING LEADS MUST BE CONNECTED TO POWER SUPPLY CONNECTION

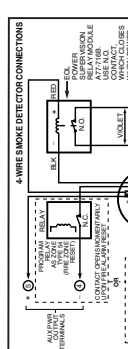
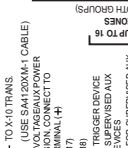
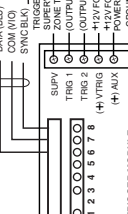
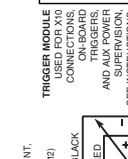

SEALED LEAD-ACID TYPE. NOT BE REPLACED FOR AT LEAST 3 HRS TO DETERMINE TOTAL STANDBY LOAD ON BATTERY. ADD 100mA TO TOTAL OF AUX. POWER OUTPUT AND REMOTE KEYPAD CURRENTS.

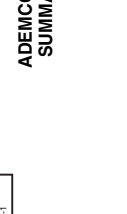
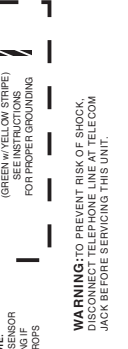
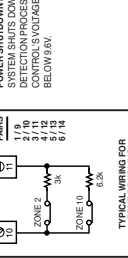
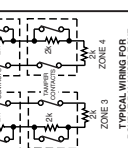
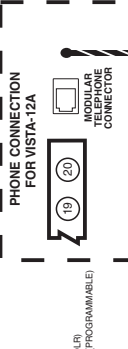
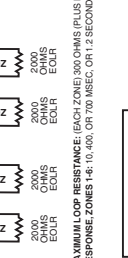
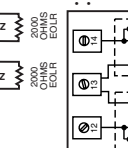
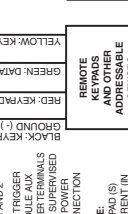
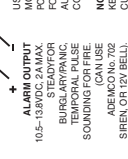
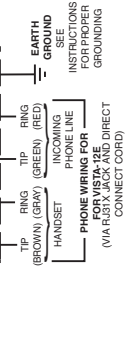
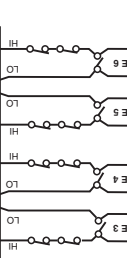
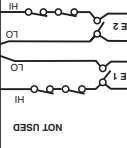
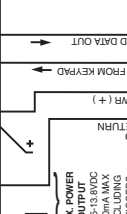
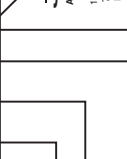
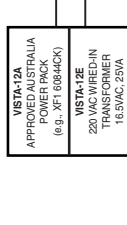
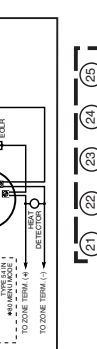
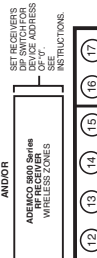
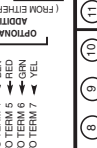
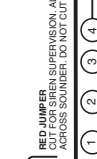

ADEMCO VISTA-12A / VISTA-12E SUMMARY OF CONNECTIONS

VISTA-12E-SOC-WO

FOR COMPLETE INFORMATION, SEE INSTRUCTIONS KIT0252-1

WARNING: TO PREVENT RISK OF SHOCK, DISCONNECT TELEPHONE LINE AT TELECOM JACK BEFORE SERVICING THIS UNIT.

POWER SHUTDOWN NOTE: SYSTEM SHUTS DOWN SENSOR DETECTION PROCESSING IF CONTROL'S VOLTAGE DROPS BELOW 9.6V.

MAXIMUM LOOP RESISTANCE: (EACH ZONE 300 OHMS PLUS EQUAL) RESPONSE ZONES 1-6: 10, 100, OR 700 MSEC. OR 1.2 SECONDS (PROGRAMMABLE)

TYPICAL WIRING FOR ZONE DOUBLING

ADEMCO N219

Honeywell

165 Eileen Way, Syosset, New York 11791

Copyright © 2005 Honeywell International Inc.

www.honeywell.com/security



K10022-1 9/04 Rev. A