

ICP-CC404

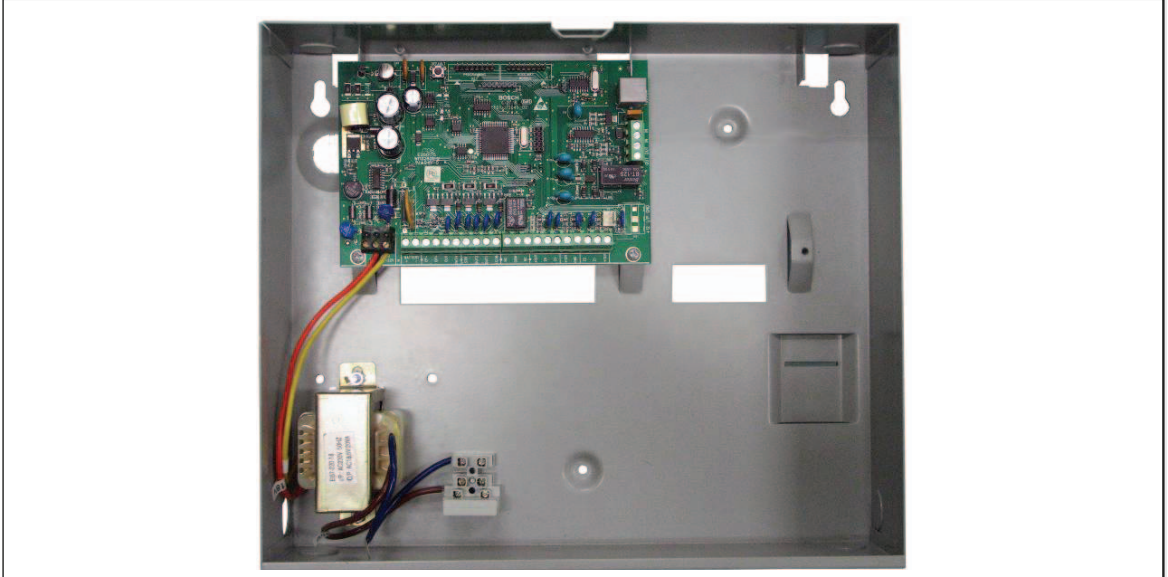

EN | User's Guide
ICP-CC404
Control Panel



BOSCH

Copyright Notice

Unless otherwise indicated, this publication is the copyright of Bosch Security Systems, Inc. (“**Bosch**”). All rights are reserved.

You may download a single copy of this publication. By downloading the publication you agree that you will: (i) only use the publication for your own reference; (ii) not commercially exploit or charge any person for the use of the publication; and (iii) not modify the publication in any way without the prior written permission of Bosch.

Except as specified above or where authorized by the Copyright Act 1968 (Cth), no part of this publication may be reproduced, transmitted, modified or stored, in any form or by any means, without the prior written permission of Bosch.

Notice of Liability

This material is designed for use by tradespeople with expertise in the installation of this product. Persons without appropriate expertise should seek assistance before attempting installation.

While care was taken in the preparation of this material, Bosch Security Systems, Inc. and its representatives are not responsible to any person or entity for any loss or damage directly or indirectly caused by information in, or any omission from, this material.

Bosch Security Systems, Inc. reserves the right to make changes to features and specifications of its products at any time without prior notification.

New Zealand Telepermit Notes

The grant of a telepermit for a device in no way indicates Telecom acceptance of responsibility for the correct operation of that device under all operating conditions.

This equipment will not be used in any manner that could constitute a nuisance to other telecom customers.

Immediately disconnect this equipment should it become physically damaged and arrange for its disposal or repair.

The transmit level from this device is set at a fixed level and because of this, there may be circumstances where the performance is less than optimal. Before reporting such occurrences as faults, please check the line with a standard telepermitted telephone and do not report a fault if the telephone performance is satisfactory.

This device is equipped with pulse dialing while the Telecom standard is DTMF tone dialing. There is no guarantee that Telecom lines will always continue to support pulse dialing.

Use of dialing, when this equipment is connected to the same line as other equipment, may give rise to bell noise and also cause a false answer condition. Should such problems occur, the user should **not** contact the Telecom Faults Service.

This equipment is set up to carry out test calls at pre-determined times. Such test calls interrupt any other calls that may be set up on the line at the same time. The timing set for such test calls should be discussed with the installer.

The timing set for test calls from this equipment may be subject to drift. If this proves to be inconvenient and your calls are interrupted, then the problem of timing should be discussed with the equipment installer. The matter should **not** be reported as a fault to Telecom Faults Service.

This equipment shall not be set up to make automatic calls to the Telecom 111 Emergency Service. This equipment should not be used under any circumstances that may constitute a nuisance to other Telecom customers.

In the event of any problem with this device, the systems battery, AC MAINS supply, and telephone line should be disconnected. The user is to arrange with the supplier of the device to make the necessary repairs.

Should the matter be reported to Telecom as a wiring fault and the fault proven to be due to this product, a call-out charge will be incurred.

Contents

1.0	Introduction	4	16.5	Test Report	13
2.0	Features	4	17.0	Event Memory Recall	13
3.0	Codepad Indicators	5	18.0	Day Alarm	13
3.1	Zone Indicators	5	19.0	Remote Arming By Telephone	13
3.2	AWAY Indicator	5	20.0	Domestic Dialing	14
3.3	STAY Indicator	5	20.1	Acknowledging Domestic Calls	14
3.4	System Disarmed	5	20.2	Programming Domestic Telephone Numbers	14
3.5	MAINS Indicator	6	20.3	Disable Domestic Dialing	14
3.6	Off Indicator/Zone Sealed	6	21.0	Basic Pager Reporting	14
3.7	On Indicator/Zone in Alarm	6	22.0	Glossary of Terms	17
3.8	FAULT Indicator	6	23.0	Installation Notes	19
3.9	Audible Indications	6	24.0	Specifications	22
4.0	Arming the System	6	Figures		
4.1	Arming in AWAY Mode	7	Figure 1:	ICP-CP508W Eight Zone LED Codepad 5	
4.2	Arming in STAY Mode 1	7	Figure 2:	ICP-CP508LW Eight Zone LCD Codepad	5
4.3	Arming in STAY Mode 2	7	Figure 3:	RE012/E: 2-Channel Keyfob Transmitter	9
4.4	Programming STAY Mode 2 Zones	8	Figure 4:	RE013/E: 4-Channel Keyfob Transmitter	9
5.0	Disarming the System	8	Figure 5:	ICP-CP508W LED Codepad Showing Audible Alarm Buttons	9
6.0	User Codes	8	Figure 6:	Basic Pager Display	16
6.1	Adding User Codes	8	Tables		
6.2	Adding Radio Remote User Codes	8	Table 1:	Zone Indicators	5
6.3	Deleting User Codes/Radio User Codes	8	Table 2:	AWAY Indicator	5
7.0	Radio Transmitter Operations	9	Table 3:	STAY Indicator	5
8.0	Alarms	9	Table 4:	MAINS Indicator	6
8.1	Duress Alarm	9	Table 5:	FAULT Indicator	6
8.2	Panic Alarm	9	Table 6:	Audible Indicators	6
8.3	Fire Alarm	10	Table 7:	Arming Methods	6
8.4	Medical Alarm	10	Table 8:	Keyfob Audible and Visual Indications	9
8.5	Tamper Alarm (Access Denied)	10	Table 9:	Fault Condition Indicators	11
9.0	Isolating Zones	10	Table 10:	Telco Arm/Disarm Dialing Digits	12
9.1	Standard Isolating	10	Table 11:	Domestic Dialing Telephone Digits	14
9.2	Code to Isolate	10	Table 12:	Zone Status Display Descriptions	15
10.0	Setting the Date and Time	10	Table 13:	System Status	15
11.0	Fault Analysis Mode	11	Table 14:	Glossary of Terms	17
11.1	AC Fail	11	Table 15:	Specifications	22
11.2	System Faults	11			
11.3	Fault Descriptions	11			
12.0	Telco Arm/Disarm Sequence (Call Forward On/Off)	11			
12.1	Telco Arm Sequence	11			
12.2	Telco Disarm Sequence	12			
13.0	Turning Outputs On/Off	12			
14.0	Reset Latching Outputs	12			
15.0	Codepad ID/Buzzer Tone Change	12			
16.0	Testing	13			
16.1	Horn Speaker Test	13			
16.2	Bell Test	13			
16.3	Strobe Test	13			
16.4	Walk Test Mode	13			

1.0 Introduction

Congratulations on selecting the ICP-CC404 Control Panel to protect you and your property. To get the most from your unit, read through this manual and familiarize yourself with the operating features of this system. In all aspects of planning, engineering, styling, operation, convenience, and adaptability, we have sought to anticipate your every possible requirement.

Programming simplicity and speed were some of the major considerations and we believe that our objectives in this area were more than satisfied.

This guide explains all aspects of operating the control panel. All system parameters and options are detailed. Suitability is left up to the individual. Every system can be tailored to meet all requirements quickly and easily.

2.0 Features

The ICP-CC404 Control Panel uses the latest in microprocessor technology to provide you with more useful features, and superior reliability and performance. The main features of the control panel are:

- Eight programmable User Codes
- STAY Mode and AWAY Mode operation
- Four programmable burglary zones
- Four programmable 24-hour zones
- Siren and/or dialer lockout per zone
- Delayed reporting
- Built-in telephone fail monitor
- Day alarm
- Remote arming
- Answering machine bypass
- Upload/download programmable
- Auxiliary output (Output 2)
- Relay output
- Eight radio remote user codes
- Entry and Exit Warning beeper
- EDMSAT – satellite siren compatible
- Separate fire alarm sound
- Dual reporting
- Sensor watch
- Dynamic battery testing
- Automatic arming and disarming
- AC fail and system fault indicators
- Walk Test Mode
- Monitored siren output (Output 1)
- Strobe output
- Telco arm and disarm sequence (call forwarding)
- 40 events in non-volatile memory

3.0 Codepad Indicators

Figure 1: ICP-CP508W Eight Zone LED Codepad

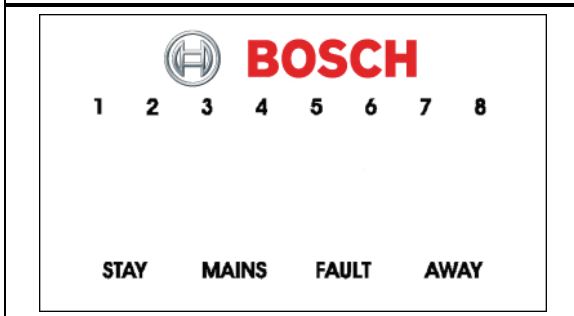
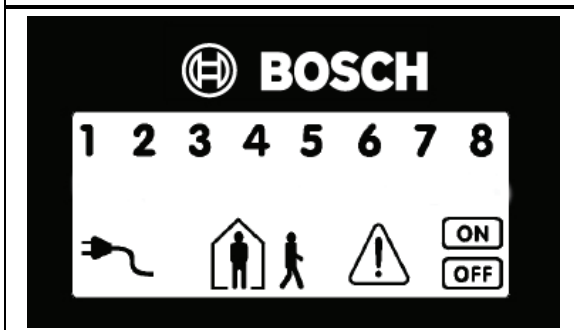

Figure 2: ICP-CP508LW Eight Zone LCD Codepad



The codepad is the communications interface between you and your alarm system. Use the codepad to issue commands. The codepad offers both visual and audible indications that guide you through general operation.

The codepad incorporates a number of indicators. Eight zone indicators show the status of each zone and four other indicators show general status.

3.1 Zone Indicators

1 2 3 The zone indicators (1 to 8) display the status of the zones. *Table 1* lists the status that the indicators display (such as, Zone Sealed/Zone Unsealed).

Status	Definition
On	Zone is unsealed.
Off	Zone is sealed.
Flashing fast (0.25 sec on/ 0.25 sec off)	Zone is in alarm.
Flashing slow (1 sec on/1 sec off)	Zone is manually isolated or selected to be isolated.

3.2 AWAY Indicator



The AWAY indicator shows the system is armed in AWAY Mode. The AWAY indicator also flashes in unison with the STAY indicator when programming the control panel.

Refer to *Section 4.1 Arming in AWAY Mode* on page 7 for information on the different methods of arming the system in AWAY Mode.

Table 2: AWAY Indicator

Status	Definition
On	System is armed in AWAY Mode.
Off	System is not armed in AWAY Mode.

3.3 STAY Indicator



The STAY indicator shows the system is armed in STAY Mode 1 or STAY Mode 2. The STAY indicator also flashes in unison with the AWAY indicator when programming the control panel.

Refer to *Section 4.2 Arming in STAY Mode 1* on page 7 and *Section 4.3 Arming in STAY Mode 2* on page 7.

Table 3: STAY Indicator

Status	Definition
On	System is armed in STAY Mode 1 or STAY Mode 2.
Off	System is not armed in STAY Mode 1 or STAY Mode 2.
Flashing twice a sec	Zone Isolating Mode or setting STAY Mode 2 zones.
Flashing once every 3 sec	Day alarm status – day alarm turned on.

3.4 System Disarmed



This indicator and the **OFF** indicator light when the system is disarmed.

3.5 MAINS Indicator



The MAINS indicator shows if the systems AC MAINS supply is normal or failed.

Table 4: MAINS Indicator

Status	Definition
On	AC MAINS power normal.
Flashing	AC MAINS supply failed.

3.6 Off Indicator/Zone Sealed



The **OFF** indicator lights when the system is disarmed and flashes when a zone becomes unsealed when disarmed. The indicator stops flashing when all zones are sealed.

3.7 On Indicator/Zone in Alarm



The **ON** indicator lights when the system is armed in AWAY Mode and flashes when an alarm occurs. The system resets this indicator after you enter a valid user code.

3.8 FAULT Indicator



The FAULT indicator lights if the system detects a system fault. Refer to *Section 11.0 Fault Analysis Mode* on page 11 for additional information on system faults.

Every time a new system fault is detected (the FAULT indicator flashes), the codepad beeps once every min. Pressing [#] once cancels the once a min beep and acknowledges the fault (the FAULT indicator lights steadily).

Table 5: FAULT Indicator

Indicator	Definition
On	There is a system fault you must correct.
Off	The system is normal. There are no faults.
Flashing	There is a system fault that must be acknowledged.

3.9 Audible Indications

Table 6 defines the audible indicators generated by the codepad buzzer.

Table 6: Audible Indicators

Indicator	Definition
One short beep	A button was pressed on the codepad, or end of Exit Time occurred when armed in STAY Mode 1 or STAY Mode 2.
Two short beeps	The system accepted your code.
Three short beeps	The system executed the requested function.
One long beep	Indicates the end of Exit Time when armed in AWAY Mode, or the requested operation was denied or aborted.
One beep every sec	Walk Test Mode is currently active or it is a warning before automatic arming takes place.
One short beep every min	There is a system fault waiting to be acknowledged.

4.0 Arming the System

There are several ways to arm the system depending on whether you are:

- Leaving the premises and you want all active zones to be in a ready state for an intruder.
- Remaining in the premises and you only want part of the system to be in a ready state for an intruder.

If a zone is not sealed at the end of Exit Time, the zone is automatically isolated and lights steadily on the remote codepad. The zone becomes an active part of the system when the zone is resealed. For example, if a window is left open after Exit Time expires, the window is not an active part of the system until the window is closed. Opening the window after Exit Time expires causes an alarm.

Table 7 defines the different methods for arming the system.

Table 7: Arming Methods

Method	Definition
AWAY Mode	Arms the entire system. Refer to <i>Section 4.1 Arming in AWAY Mode</i> .
STAY Mode 1	Arms all zones except those programmed by the installer to be automatically isolated. Refer to <i>Section 4.2 Arming in STAY Mode 1</i> .
STAY Mode 2	Arms all zones except those programmed by the Master Code holder to be automatically isolated. Refer to <i>Section 4.3 Arming in STAY Mode 2</i> .

Forced Arming

Arming the system when a zone is not sealed is known as forced arming. If the system is not armed and a long beep sounds, forced arming is not permitted. If this is the case, ensure that all zones are sealed or manually isolated before arming the system.

4.1 Arming in AWAY Mode

When you leave your premises and require all zones to be in a ready state to detect intrusion, arm the system in AWAY Mode. When returning to your premises, disarm your system (refer to *Section 5.0 Disarming the System*) so you do not sound a false alarm.

There are two different methods for arming the system in AWAY Mode. One method is standard and is always available. The other method is optional and might be disabled by your installer.

To arm in AWAY Mode using the first method:

Enter your user code and press [#] (for example, [2 5 8 0 #]).
Two beeps sound and the AWAY indicator lights. Exit Time starts.

To arm in AWAY Mode using the second method:

Hold down [#] until two beeps sound.
The AWAY indicator lights and Exit Time starts.

4.2 Arming in STAY Mode 1

STAY Mode 1 is only used when the perimeter and unused areas of the premises must be armed to detect if an intruder is entering the premises. At the same time, it allows you to move freely within an area that is automatically isolated.



Only your security company can program zones automatically isolated in STAY Mode 1.

There are two different methods for arming the system in STAY Mode 1. One method is standard and is always available. The other method is optional and might be disabled by your installer.

Entry Guard Timer for STAY Mode 1

When arming the system in STAY Mode 1, an optional entry timer called Entry Guard Timer for STAY Mode 1 is available. Use this entry timer to delay the sirens if a zone is not automatically isolated and activates an alarm. Entry Guard Timer for STAY Mode 1 is the delay time used for all zones except 24-hour zones when the system is armed in STAY Mode 1 or STAY Mode 2.

If the Entry Guard Timer for STAY Mode 1 is programmed and a zone not automatically isolated is activated, the codepad beeps twice per sec until the entry timer expires or the system is disarmed. If the alarm condition is not reset by entering your user code and pressing [#] (for example, [2 5 8 0 #]) before the entry timer expires, the sirens sound an alarm. Only your installer can program this feature.

To arm in STAY Mode 1 using the first method:

Enter your user code and press [*] (for example, [2 5 8 0 *]).
Two beeps sound and the STAY indicator lights. Exit Time starts counting.

Any zones programmed to be automatically isolated in STAY Mode 1 flash until Exit Time expires. At the end of Exit Time, all zones selected to be automatically isolated turn off and the codepad gives one short beep.

To arm in STAY Mode 1 using the second method:

Hold down [*] until two beeps sound.
The STAY indicator lights and Exit Time starts.

Any zones programmed to be automatically isolated in STAY Mode 1 flash until Exit Time expires. At the end of Exit Time, the zone indicators turn off and the codepad sounds one short beep.

4.3 Arming in STAY Mode 2

STAY Mode 2 is used only when you want to arm the perimeter and unused areas of the premises to detect an intruder while you move freely within an automatically isolated area. Any Master Code user can program zones to be automatically isolated in STAY Mode 2.

Entry Guard Timer for STAY Mode 2

When arming the system in STAY Mode 2, an optional entry timer called Entry Guard Timer for STAY Mode 2 is available. Use this entry timer to delay the sirens if a zone is not automatically isolated, but activates an alarm. Entry Guard Timer for STAY Mode 2 is the delay time used for all zones, except 24-hour zones, when the system is armed in STAY Mode 1 or STAY Mode 2.

If the Entry Guard Timer for STAY Mode 2 is programmed and a zone not automatically isolated activates an alarm, the codepad beeps twice a sec until the entry timer expires or you disarm the system. If you do not reset the alarm by entering your user code and pressing [#] (for example, [2 5 8 0 #]) before the entry timer expires, the system activates the sirens to sound an alarm. Only your installer can program this option.

To arm in STAY Mode 2:

Hold down [0] until two beeps sound.
The STAY indicator lights and Exit Time starts.

Any zones programmed to be automatically isolated in STAY Mode 2 flash until Exit Time expires. At the end of Exit Time, the indicators turn off for all zones selected to be automatically isolated and the codepad sounds one short beep.

4.4 Programming STAY Mode 2 Zones

If you have a Master Code, you can only program zones to be automatically isolated in STAY Mode 2.

How to Program STAY Mode 2 Zones

1. Enter your four-character Master Code and press [4 #] key (for example, [2 5 8 0 4 #]). Three beeps sound and the STAY indicator flashes.
2. Enter the zone number to automatically isolate and press [*] (for example, [1 *] for Zone 1 or [2 *] for Zone 2). The selected zone flashes. If you make a mistake, enter the same zone number and press [#] to clear the incorrect zone. To select additional zones to automatically isolate in STAY Mode 2, repeat *Step 2* as many times as necessary.
3. After you select the zones to automatically isolate in STAY Mode 2, press [#] to exit from this mode. Two beeps sound and the STAY and AWAY indicators turn dark.

5.0 Disarming the System

When you enter the premises after the system is armed in AWAY Mode, or if you armed the system in STAY Mode 1 or STAY Mode 2, you must disarm the system before entry time expires to disable detection devices that activate an alarm. Only your installer can program the entry time.

If there was an alarm before you disarm the system, a flashing zone indicator shows a previous alarm on that zone.

To disarm the system:

Enter your user code and press [#] key (for example, [2 5 8 0 #]). Two beeps sound.

6.0 User Codes

6.1 Adding User Codes

Only the Master Code holder can add or change other system user codes, including the Master Code. The Master Code holder can program up to eight user codes for the system.

To add a user code:

1. Enter your four-character Master Code and press [1 #] (for example, [2 5 8 0 1 #]). Three beeps sound and the STAY and AWAY indicators flash.
2. Enter the user code number (1 to 8) and press [#] (for example, [2 #] for User 2, or [8 #] for User 8). Two beeps sound and the selected user number appears on the codepad indicators.
3. Enter the digits required for the new code and press [#] (for example, for user code 5768, enter [5 7 6 8 #]). Two beeps sound and the STAY and AWAY indicators turn off. To add or change other user codes, repeat this procedure as many times as necessary.

6.2 Adding Radio Remote User Codes

Only the Master Code holder can add or change other system user codes, including the Master Code. The Master Code holder can program up to eight radio user codes (User Codes 9 to 16) for the system.

To add a radio remote user code:

1. Enter your four-character Master Code and press [1 #] (for example, [2 5 8 0 1 #]). Three beeps sound and the STAY and AWAY indicators flash.
2. Enter the radio remote user code number (9 to 16) and press [#] (for example, [9 #] for User 9, or [1 6 #] for User 16). Two beeps sound and the selected user number appears on the codepad indicators.
3. Press any button on the keyfob so the system learns the ID number. Two beeps sound and the STAY and AWAY indicators turn off. To add or change other radio remote user codes, repeat this procedure as many times as required.

6.3 Deleting User Codes/Radio User Codes

Only the Master Code holder can delete other system user codes.

To delete a user code:

1. Enter your four-character Master Code and press [1 #] (for example, [2 5 8 0 1 #]). Three beeps sound and the STAY and AWAY indicators flash.
2. Enter the user code number (User Code 1 to 8, or Radio User Code 9 to 16) and press [#] (for example, [2 #] for User 2, [1 6 #] for User 16). Two beeps sound and the selected user number appears on the codepad indicators.
3. Press the [*] key to delete the selected user code. Two beeps sound and the STAY and AWAY indicators turn off. To delete other user codes, repeat this procedure as many times as required.

7.0 Radio Transmitter Operations

Figure 3: RE012/E: 2-Channel Keyfob Transmitter

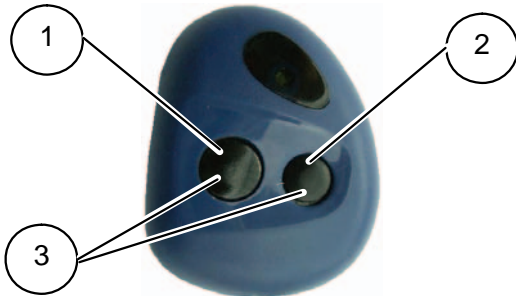

- 1 – Button 1: Arm or disarm in AWAY Mode
- 2 – Button 2: Arm or disarm STAY Mode
- 3 – Buttons 1 and 2: Press both buttons at the same time to activate Panic alarm.

Figure 4: RE013/E: 4-Channel Keyfob Transmitter

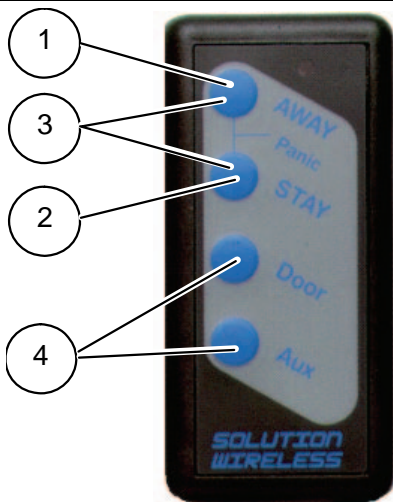

- 1 – Button 1: Arm or disarm in AWAY Mode
- 2 – Button 2: Arm or disarm in STAY Mode
- 3 – Buttons 1 and 2: Press both buttons at the same time to activate Panic alarm.
- 4 – Buttons 3 and 4: Your security company can program these buttons for optional operation, such as operating a garage door.

Audible and Visual Indications

When using hand-held keyfob transmitters to operate the system, your security company can program the keyfobs to sound the horn speaker or operate the blue strobe light. These indications allow you to operate the system from outside the premises with confidence.

Table 8: Keyfob Audible and Visual Indications

Indication	Definition
One beep	System disarmed.
Two beeps	System armed in AWAY Mode.
Two-tone beep	System armed in STAY Mode.
3-sec strobe	System disarmed.
6-sec strobe	System armed in AWAY or STAY Mode.

8.0 Alarms

8.1 Duress Alarm

A codepad duress alarm is used as a silent hold-up alarm. This only occurs when a user adds 9 to the end of a valid user code when disarming the system (for example, [2 5 8 0 9 #]). A duress alarm is only useful if your system reports back to a monitoring station or pocket pager, because domestic reporting (such as a mobile phone) cannot decipher which type of alarm occurred.

Figure 5: ICP-CP508W LED Codepad Showing Audible Alarm Buttons

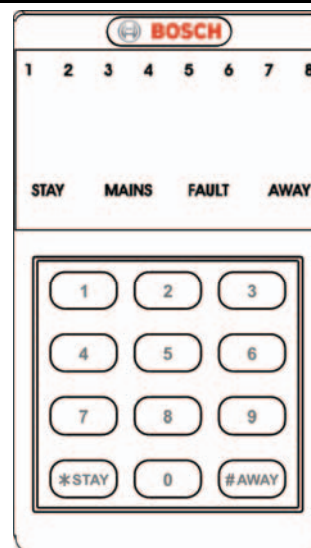

8.2 Panic Alarm

An audible alarm activates when you press [1] and [3] or [*] and [#] simultaneously. Contact your installer to disable the ability to activate the codepad panic alarm or to silence the codepad panic alarm.

8.3 Fire Alarm

The horn speaker emits a distinct fire sound when you press [4] and [6] simultaneously. Contact your installer to disable the ability to activate the codepad fire alarm or to silence the codepad fire alarm.

8.4 Medical Alarm

An audible alarm activates when you press [7] and [9] simultaneously. Contact your installer to disable the ability to activate the codepad medical alarm or to silence codepad medical alarm.

8.5 Tamper Alarm (Access Denied)

The tamper alarm restricts the number of times someone can attempt to use an invalid user code to operate the system. When the number of incorrect code attempts equals the number programmed by your installer, the system activates an alarm. If reporting back to a security monitoring station, the system sends an Access Denied Report.

To shut down and lock out a codepad for a period of time (0 to 150 sec), ask your installer to program this feature.

9.0 Isolating Zones

Isolating zones allow you to manually disable one or more zones before arming the system. Once a zone is isolated, you can access that zone during the armed state without activating an alarm.

For example, you might need to isolate a zone because before arming the system a PIR detector might generate a false alarm, or you need to leave a pet inside a particular zone while away.

Isolating zones is performed by one of two methods. The second method is optional and only allows those user codes programmed by your installer access to isolate zones.

9.1 Standard Isolating

Standard isolating allows all operators to isolate zones without knowing a valid user code.

To isolate a zone:

1. Press [*] twice to enter Isolating Mode. Three beeps sound and the STAY indicator flashes.
2. Enter the zone number (1 to 8) and press [*] (for example, [1 *] for Zone 1, or [2 *] for Zone 2). Each zone to isolate has a corresponding zone indicator that flashes. If you selected an incorrect zone to isolate, enter the incorrect zone number again and press [*]. Repeat *Step 2* if you are isolating more than one zone, until all zones you want to isolate are selected.

3. Press [#] after you isolate all selected zones. Two beeps sound and the system returns to the disarmed state.

9.2 Code to Isolate

Only the user codes with the Code to Isolate priority level can isolate zones. If any user code has this priority level, the standard isolating method (refer to *Section 9.1 Standard Isolating*) does not function.

To isolate a zone:

1. Press [*], enter your user code, and press [*] again to enter Isolating Mode (for example, [* 2 5 8 0 *]). Three beeps sound and the STAY indicator flashes.
2. Enter the zone number (1 to 8) and press [*] (for example, [1 *] for Zone 1 or [2 *] for Zone 2). Each zone to isolate has a corresponding zone indicator that flashes. If you selected an incorrect zone to isolate, enter the incorrect zone number again and press [*]. If you are isolating more than one zone, repeat *Step 2* until you select the zones you want to isolate.
3. Press [#] after all selected zones are isolated. Two beeps sound and the system returns to the disarmed state.

10.0 Setting the Date and Time

Programming the date and time is only required when you need functions such as automatic test reports, automatic arming, and history events to operate correctly.

To program the date and time:

1. Enter your Master Code and press [6 #] (for example, [2 5 8 0 6 #]). Three beeps sound and the STAY and AWAY indicators flash.
2. Enter the day, month, year, hour, and minute using the (DD, MM, YY, HH, MM) format (that is, DD = day of the month, MM = month of the year, YY = current year, HH = hour of the day, MM = minute of the day).



When programming the hour of the day, you must use a 24-hour format.

3. Press [#] to exit and return to the disarmed state. Two beeps sound and the STAY and AWAY indicators turn off. A long beep sounds if you incorrectly entered the date and time.

11.0 Fault Analysis Mode

If a fault occurs, the FAULT or MAINS indicators flash and the codepad beeps once every min.

11.1 AC Fail

If the AC MAINS supply fails, the MAINS indicator flashes until the AC MAINS supply is restored. Pressing [#] once acknowledges the fault and stops the codepad from beeping once every min.

11.2 System Faults

To determine all system faults other than the AC MAINS supply, enter Fault Analysis Mode:

1. Hold down [5] until two beeps sound. The FAULT indicator lights steadily and the STAY and AWAY indicators flash in unison. Any lit zone indicators indicate the type of fault that occurred. Refer to *Table 9* for the list of system faults that can occur.
2. To further determine the type of fault condition, hold down the key that corresponds to the lit zone indicator.
3. To exit from Fault Analysis Mode and return to the disarmed state, press [#]. The FAULT indicator remains lit and the codepad stops beeping once per min.

11.3 Fault Descriptions

Zone LED	FAULT Condition
1	Battery Fail
2	Date/Time
3	Sensor Watch
4	Horn Speaker Fail
5	Telephone Line Fail
6	EEPROM Fail
7	AUX Power Supply Fail
8	Communication Fail

Battery Fail

A battery fail fault registers when the system detects a low capacity backup battery. The system automatically performs a Battery Test every 4 hours and every time the system is armed.

Date and Time

The date and time fault registers every time the system powers down. This type of fault does not cause the FAULT indicator to display on the codepad unless your installer programmed the automatic arming time. Refer to *Section 10.0 Setting the Date and Time* to program the date and time.

Sensor Watch Fail

A sensor watch fault registers because one or more detection devices failed to notice any movement during the disarmed state for the time period programmed by your installer. The fault clears when the zone in question detects movement and is reset.

While in Fault Analysis Mode, hold down [5] until two beeps sound.

The indicator corresponding to the faulted zone lights.

Horn Speaker Fail

A horn speaker failure fault registers when the system detects the horn speaker is disconnected. This fault clears once the horn speaker is reconnected. Your installer must program the system for this feature to operate.

Telephone Line Fail

A telephone line failure fault registers when the system detects the telephone line is disconnected from the control panel. Your installer must program the system for this feature to operate.

EEPROM Fault

An EEPROM failure fault registers when the system detects an internal checksum error. Contact your installer if this fault occurs.

AUX Power Supply Fail

An AUX power supply failure fault occurs when either of the two 1 A AUX power supplies fail. Contact your installer if this fault occurs.

Communication Fail

A communication fail fault registers when the control panel fails to communicate with the receiving party (for example, a monitoring company, mobile phone, pocket pager, and so on). The communication fault clears after the control panel successfully reports to the receiving party.

12.0 Telco Arm/Disarm Sequence (Call Forward On/Off)

12.1 Telco Arm Sequence

Use this section to program the Call Forward – Immediate On sequence or Call Forward – No Answer sequence to automatically operate when you arm the system in AWAY Mode. This feature is only available if your telecommunications provider has the call-forward option.



The examples given in this feature are only applicable to Australia.

Call Forward – Immediate On

You can redirect calls to anywhere in Australia, including mobile phones, pagers, and answering services. When Call Forward is turned on, your telephone does not ring.

Call Forward – No Answer

If your telephone is not answered within 20 sec, this feature redirects all incoming calls to another number anywhere in Australia. When this feature is enabled, you can still make outgoing calls.

Table 10: Telco Arm/Disarm Dialing Digits

Digit Required	Number to Program	Digit Required	Number to Program
0	0	8	8
1	1	9	9
2	2		
3	3	*	*1
4	4	#	*2
5	5	4-sec pause	*3
6	6	break	*4
7	7		

To program the Telco Arm Sequence:

- Enter your four-character Master Code and press [3 #] (for example, [2 5 8 0 3 #]). Three beeps sound and the STAY and AWAY indicators flash.
- Press [1 #] to select the Telco Arm Sequence. Three beeps sound.
- Enter the call forward sequence (for example, [* 6 1][Phone Number][#] to program the Call Forward - No Answer sequence, or [* 2 1][Phone Number][#] to program the Call Forward Immediate sequence).
To program a "*" in the Telco Arm Sequence, enter [* 1]. To program a "#" in the Telco Arm Sequence, enter [* 2].
- Press [#] when finished. Two beeps sound, and the STAY and AWAY indicators turn off.



To disable the Telco Arm Sequence, enter the call forward sequence as [* 4] (break) for *Step 3*.

12.2 Telco Disarm Sequence

This feature automatically disables the call forward sequence when disarming the system.

To program the Telco Disarm Sequence:

- Enter your four-character Master Code and press [3 #] (for example, [2 5 8 0 3 #]). Three beeps sound and the STAY and AWAY indicators flash.

- Press [2 #] to select the Telco Disarm Sequence. Three beeps sound.
- Enter the call forward disable sequence (for example, [# 6 1 #] to disable the No Answer Call Forward sequence, or [# 2 1 #] to disable the Call Forward Immediate sequence).
To program a "#" in the Telco Disarm Sequence, enter [* 2].
- Press [#] when finished. Two beeps sound, and the STAY and AWAY indicators turn off.



To disable the Telco Disarm Sequence, enter the call forward sequence as [* 4] (break) for *Step 3*.

13.0 Turning Outputs On/Off

This feature only applies if your installer set up an output to be turned on or off by the codepad. Your installer can program up to three outputs to control a pool pump, outside lighting, and so on.

To turn an output on or off:

- Enter your Master Code and press [5 #] (for example, [2 5 8 0 5 #]). Three beeps sound and the STAY and AWAY indicators flash.
- Enter the output number (1 to 3) you want to turn on or off.
- Press [#] to turn the output on, or press [*] to turn the output off. Three beeps sound if you turn the output on, and two beeps sound if you turn the output off. Repeat *Step 2* and *Step 3* to turn other outputs on or off.
- Press [#] to exit from this function. Two beeps sound and the STAY and AWAY indicators turn off.

14.0 Reset Latching Outputs

This feature only applies if your installer programmed an output to latch (remain on) until you acknowledge the event that turned on the output.

To reset latching outputs:

Hold down [7] until two beeps sound. The output resets.

15.0 Codepad ID/Buzzer Tone Change

Hold down [8] continuously to change the tone of the codepad buzzer.

There are 50 different tones, from 1500 Hz to 5000 Hz. If multiple codepads are installed, each codepad can sound a different tone.

16.0 Testing

There are five functions for testing that your system operates correctly.

16.1 Horn Speaker Test

Press and hold [1] until two beeps sound.
The horn speaker sounds for 2 sec.

16.2 Bell Test

Press and hold [2] until two beeps sound.
The bell output turns on for 2 sec.

16.3 Strobe Test

1. Press and hold [3] until three beeps sound.
The strobe flashes.
2. Press and hold [3] until two beeps sound.
The strobe stops flashing.

16.4 Walk Test Mode

Use Walk Test Mode to test the proper operation of detection devices. Every time you test a zone, the codepad sounds one long beep and the horn speaker sounds one short beep to indicate the zone was activated when testing.

1. Enter your four-character Master Code and press [7 #] (for example, [2 5 8 0 7 #]).
Three beeps sound, and the STAY and AWAY indicators flash. The codepad beeps once per sec while the system is in Walk Test Mode.
2. Activate the zones you want to test.
The codepad sounds one long beep and the horn speaker sounds one short beep each time a zone is faulted (unsealed) and restored.
3. When you finish testing the zones, press [#] to exit from this mode.
Two beeps sound, and the STAY and AWAY indicators turn off. The system returns to the disarmed state.

16.5 Test Report

This feature only applies if your system reports by telephone. Press and hold [9] until two beeps sound. The system sends a Test Report without sounding the sirens.

17.0 Event Memory Recall

Use this function to replay the last 40 system events that occurred. The event memory history replays all alarms, and arming and disarming of the system in AWAY Mode, STAY Mode 1, and STAY Mode 2.



The system cannot differentiate between arming the system in STAY Mode 1 or STAY Mode 2.

To enter Event Memory:

Enter your four-character Master Code and press [8 #] (for example, [2 5 8 0 8 #]).
Three beeps sound. The last 40 events appear one at a time by the codepad indicators, starting from the most recent event. A beep sounds as each event appears.

18.0 Day Alarm

Day alarm allows the system to monitor a combination of zones when the system is disarmed by beeping the codepad buzzer. Only your installer can program Zones 1 to 4 to operate for day alarm.

Example

You can set up a day alarm at the front door of a shop with a pressure mat or electronic beam that customers activate as they enter and exit from the shop. As the customers walk onto the pressure mat or break the electronic beam, the codepad buzzer beeps.

To turn day alarm on:

Hold down [4] until three beeps sound.
Day alarm turns on. If a zone programmed for day alarm operation is activated when the system is disarmed, the codepad beeps.

To turn day alarm off

Hold down [4] until two beeps sound.
Day alarm turns off.

19.0 Remote Arming By Telephone

Use this feature to arm your system by telephone from any remote location. For security reasons, you cannot disarm the system using this method. This feature requires a touch-tone telephone. Remote arming works only if your installer programmed this feature.

To arm your system remotely by telephone:

1. Call the telephone number connected to your control panel.
When the control panel answers the incoming call, a short jingle sounds.
2. To arm the system, press [*] on the touch-tone telephone for 1 to 3 sec.
If you hear modem tones when the control panel answers the incoming call, the system is programmed for remote programming functions by your installer. Wait for a pause between the tones before you press [*].
After you release [*] on the touch-tone telephone, two beeps sound. The system is armed in AWAY Mode.

- Hang up the telephone.
The system remains armed.



If your installer programmed answering machine bypass, you must call the control panel twice to connect to the system. For example, call the telephone number for the control panel, let the call ring no more than four times, and then hang up the telephone. Wait at least 8 sec and call the control panel again.

20.0 Domestic Dialing

Domestic dialing enables the control panel to call your mobile phone or a relative or friend if the system detects an alarm. You can program up to three different telephone numbers to call when an alarm occurs. Although only your installer can set the system to report in the domestic format, the Master Code holder can change the domestic telephone numbers at any time.

20.1 Acknowledging Domestic Calls

If an alarm occurs, the system calls the first programmed telephone number. When you answer an incoming call, the system sounds a repeating siren tone followed by a pause, continuously for 2 min (for example, siren tone, pause, siren tone, and pause).

If you do not acknowledge the call from the control panel during a pause between siren tones, the control panel hangs up after 2 min, and calls the next telephone number.

Press [*] for 1 to 3 sec during the pause to acknowledge the call.

If you acknowledge the call, the control panel does not call any more phone numbers for that event. If the call is successfully acknowledged, a tone of decreasing pitch sounds.

Table 11: Domestic Dialing Telephone Digits

Digit Required	Number to Program	Digit Required	Number to Program
0	0	8	8
1	1	9	9
2	2		
3	3	*	*1
4	4	#	*2
5	5	4-sec pause	*3
6	6	break	*4
7	7		

20.2 Programming Domestic Telephone Numbers

If your system is configured for domestic dialing, the Master Code holder can program the telephone numbers the control panel calls if an alarm occurs.

To program telephone numbers:

- Enter your four-character Master Code and press [* #] (for example, [2 5 8 0 2 #]).
Three beeps sound and the STAY and AWAY indicators flash.
If there are telephone numbers already programmed, the numbers appear one digit at a time by the codepad indicators.
If there are no telephone numbers programmed, another two beeps sound after entering this mode. These two beeps are normally heard after the last digit of the last telephone number appears.
- Enter the first telephone number (for example, [9 6 7 2 1 7 1 7]).
As you enter each digit, the corresponding codepad indicators light.
- To program another telephone number, press [* 4] and repeat *Step 2*.
This inserts a break between the first telephone number and the second telephone number.
- Press [#] to exit from this function.

20.3 Disable Domestic Dialing

To suspend domestic dialing (for example, you are moving and do not want the system to continue calling your mobile phone):

- Enter your four-character Master Code and press [2 #] (for example, [2 5 8 0 2 #]).
Two beeps sound and the STAY and AWAY indicators flash.
- Press [* 4 #].
The STAY and AWAY indicators turn off.

21.0 Basic Pager Reporting

This feature only applies if your system reports to a pocket pager. Basic pager reporting requires some interpretation of the numbers that appear on the display. It is possible to differentiate between 1000 different systems when a number of control panels report to the one pocket pager.

Subscriber ID Number

This is the identification number of the control panel. Only your installer can program this number.

Zone Status

The zone status display shows the status of each zone (1 to 8). *Table 12* describes each number of the zone status display.

Display	Zone Description
0	Normal. The corresponding zone is sealed.
1	Alarm. The corresponding zone is unsealed and in alarm.
2	Bypassed. A system operator manually isolated the corresponding zone. Refer to <i>Section 9.0 Isolating Zones</i> for information about manually isolating a zone(s) before arming the system.
3	Trouble. A zone was unsealed when Exit Time expired.

System Status

The system status information is divided into the four digits identified in *Table 13*.

Digit	Description
First	8 = the system is disarmed 9 = the system is armed
Second	Identifies the codepad alarm activated by the operator: 0 = No Codepad Alarm 1 = Codepad Panic or Duress Alarm 2 = Codepad Fire Alarm 3 = Codepad Medical Alarm
Third	0 = AC Supply is normal 1 = AC Supply failed
Fourth	0 = System Normal – There are no faults. 1 = System Fault – The control panel registered a fault.

Figure 6 on page 16 shows a transmission from a control panel with an ID number of 678, and Zone 2 in alarm. *Figure 6* on page 16 also shows Zone 3 is manually isolated and the system is armed.

Figure 6: Basic Pager Display

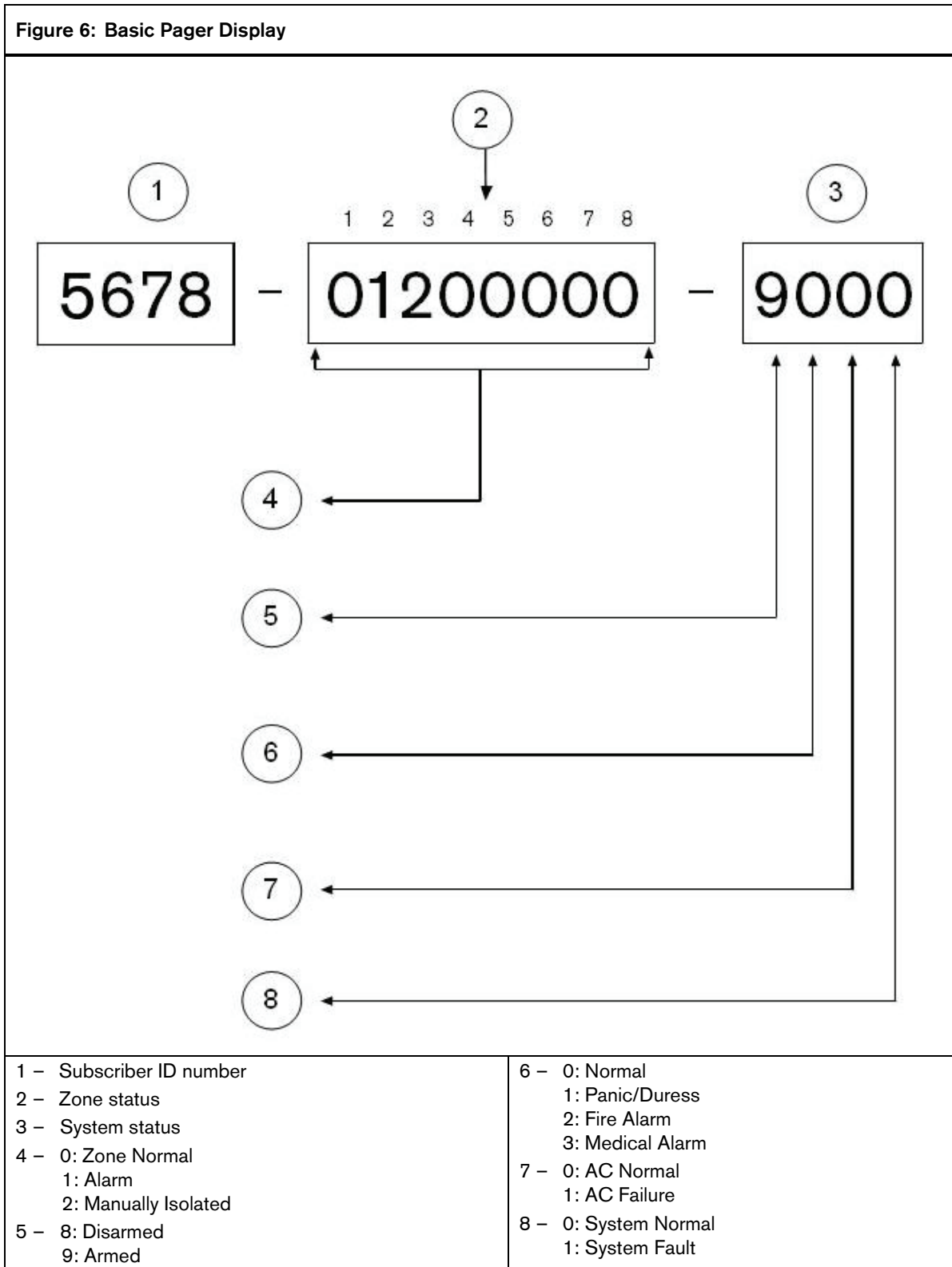

22.0 Glossary of Terms

Table 14: Glossary of Terms

Term	Description
24-hour zone	A monitored input where tamper switches and emergency switches can be connected. If one of these switches is violated at any time (whether the system is armed or disarmed), an alarm is reported.
alarm condition	The status when an alarm system is armed and one of the detection devices is violated. A 24-Hour zone (for example, a smoke detector) can activate when the system is armed or disarmed.
answering machine bypass	A condition that enables connection with the control panel for remote arming or remote programming operations when there is an answering machine or facsimile machine on the same telephone line.
Armed (System ON)	A status in which the system is ready to accept alarms.
automatic arming	Programming that allows the system to arm automatically at the same time each day in AWAY Mode or STAY Mode 1.
automatic disarming	Programming that allows the system to disarm automatically at the same time each day in AWAY Mode or STAY Mode 1.
AWAY Mode	The mode used to arm your system when you leave your premises.
codepad	A device that allows you to perform all functions such as arming, disarming, and programming of your alarm system.
day alarm	Programming that allows a combination of zones to be monitored while the system is disarmed.
detector	A unit installed as a satellite component in a security system designed to detect an intruder within a protected area. Some common forms of detection devices are passive infrared, smoke, photo electric beams, reed switches, and vibration sensors.
disarmed	A system status that does not accept alarms, except for 24-hour zones.
dynamic battery testing	A method used to monitor and test the condition of your backup battery.
entry delay	A programmed delay of the system alarm responses that allows a person to enter a building through the entry door to turn the system off.
external equipment	Any device connected to a security system, such as a detector, codepad, or siren.
force arming	A method of overriding the safety feature that prevents arming with a faulted zone on a control panel.
hand-over delay	If a system is armed and Zone 1 is violated, the entry delay starts timing. If Zone 2 is violated, the entry delay time is handed over to the Zone 2 and so on, to Zones 3 and 4. This is known as sequential hand-over delay.
hand-held radio remote control	A device used to arm and disarm a security system or to cause a panic alarm.
isolate	A method of manually disabling (isolating) one or more zones before arming the system.
master code	A numeric code used for arming and disarming the system, and for allowing access to all functions available through the codepad.
monitoring station	A secure location where a digital receiver monitors a number of alarm systems and deciphers their alarm transmission reports so the operator can advise the appropriate authorities to take immediate action.
panic	A condition or type of alarm in which the user requires either immediate police or medical assistance.
sealed	Refers to a zone's status. If a zone is sealed, the detection devices are not violated and the zone indicator is not lit (that is, a reed switch is closed or a detector is on standby waiting for an intrusion).

Table 14: continued

Term	Description
sensor watch	A feature that allows the control panel to recognize when detection devices might have stopped working. Sensor watch monitors the operation of a zone over a programmed time period.
silent alarm	An alarm that sounds only at a remote location, and gives no obvious local indication that an alarm was sent out.
STAY Mode 1	A condition that automatically isolates certain zones when the security system is armed in this mode. Only the installer can program these zones.
STAY Mode 2	A condition that automatically isolates certain zones when the security system is armed in this mode. The Master Code holder can program these zones.
telco arming sequence	A feature that automatically diverts a telephone number to another telephone when a security system is armed in AWAY Mode, the same as using call forwarding.
telco disarming sequence	An automatic suspension of diverting of the telephone when the system is disarmed.
unsealed	Refers to a zone's status. If a zone is unsealed, the detection devices are violated and the zone indicator is lit (that is, a reed switch is open or a detector noted an intrusion).
user code	A numeric code used to arm and disarm the system.
zone	A monitored input used to activate an alarm. A zone might be set up to activate an alarm only when the system is armed or to operate whether the system is armed or disarmed.

Zone Description

Describe each zone and mark the zones that are programmed to be automatically isolated in STAY Mode 1 or are programmed for day alarm operation.

		Isolated In STAY Mode 1	Day Alarm Enabled
Zone 1	_____	<input type="checkbox"/>	<input type="checkbox"/>
Zone 2	_____	<input type="checkbox"/>	<input type="checkbox"/>
Zone 3	_____	<input type="checkbox"/>	<input type="checkbox"/>
Zone 4	_____	<input type="checkbox"/>	<input type="checkbox"/>

User Code Names

		Master Code	
Default = 2580	User Code 1 _____	<input checked="" type="checkbox"/> Y	User Code 9 _____
	User Code 2 _____	<input type="checkbox"/>	User Code 10 _____
	User Code 3 _____	<input type="checkbox"/>	User Code 11 _____
	User Code 4 _____	<input type="checkbox"/>	User Code 12 _____
	User Code 5 _____	<input type="checkbox"/>	User Code 13 _____
	User Code 6 _____	<input type="checkbox"/>	User Code 14 _____
	User Code 7 _____	<input type="checkbox"/>	User Code 15 _____
	User Code 8 _____	<input type="checkbox"/>	User Code 16 _____

Entry/Exit Times

Entry Timer 1 _____ Exit Time _____
 Entry Timer 2 _____ Entry Guard Time _____

Arming Options

Single Button Arming YES NO Forced Arming YES NO
 Single Button Disarming YES NO Remote Arming By Telephone YES NO
 Automatic Arming (AWAY Mode) YES NO Automatic Arming Time _____ AM/PM
 Automatic Arming (STAY Mode) YES NO Automatic Disarming Time _____ AM/PM

Output Descriptions

Output 1 _____ Output 3 _____
 Output 2 _____ Output 4 _____

Isolating Method

Standard Isolating YES NO
 Code To Isolate YES NO

Communication Options

Back To Base Reporting YES NO
 Domestic Reporting YES NO Domestic Reporting – Number Of Beeps

Other System Information

Siren Run Time Minutes
 Sensor Watch Time Increments in Days
 Can Your System Be Serviced By Another Technician YES NO If Yes, Installer's Code _____

24.0 Specifications

Temperature Range	-10°C to +45°C (+14°F to +113°F)
Humidity	10% to 95%
Power Source	TF008 Plug Pack – 240 VAC/18 VAC @ 1.3 A
Standby Current	65 mA
Current Draw In Alarm	115 mA
Current Draw In Alarm with Codepad	105 mA
Backup Battery	6 Ah/12 VDC Rechargeable sealed lead acid battery
Dimensions (case, packed in carton)	30.6 cm x 26.2 cm x 8.4 cm (12.1 in. x 10.3 in. x 3.3 in.)
Weight	2.5 kg (5.5 lb)
Supplier Code	N771
New Zealand Telepermit	PTC 211/98/085



The ICP-CC488 Control Panel is designed to comply with A-Tick.



Test the sirens, strobe, and zones at weekly intervals. Refer to *Section 16.0 Testing* on page 13 for further information.

Index

24-Hour Zones	20	Battery Fail	14
AC Mains Fail	14	Date and Time	14
Alarm Condition	20	EEPROM Fault	14
Alarms		Horn Speaker Fail	14
Duress	11	Sensor Watch Fail	14
Fire	12	Telephone Line Fail	14
Medical	12	Fault Descriptions	14
Panic	12	Communciation Fail	14
Tamper (Access Denied)	12	System Fault	14
Answering Machine Bypass	20	FAULT Indicator	7
Armed	20	Features	4
Arming		Fire Alarm	12
AWAY Mode	8	Forced Arming	8, 20
STAY Mode 1	8	Hand Held Remote Control	20
STAY Mode 2	8	Handover Delay	20
Telephone Arming	17	Horn Speaker Fail	14
Audible Indications	7	Horn Speaker Test	16
Automatic Arming	20	Isolating	20
Automatic Disarming	20	Isolating Zones	12
AUX Power Supply Fail	14	Code to Isolate	12
AWAY Indicator	6	Standard Isolating	12
AWAY Mode	8, 20	MAINS Indicator	7
Battery Fail	14	Master Code	20
Battery Testing	20	Medical Alarm	12
Bell Test	16	Monitoring Station	20
Codepad	20	Off Indicator	7
Duress Alarm	11	On Indicator	7
Fire Alarm	12	Pager Reporting	18
Medical Alarm	12	Panic Alarm	12, 20
Panic Alarm	12	Radio User Codes	9, 10
Tamper Alarm	12	Remote Arming	17
Codepad Indicators		Remote Control	20
Audible Indications	7	Sealed	20
AWAY Indicator	6	Sensor Watch	20
FAULT Indicator	7	Sensor Watch Fail	14
MAINS Indicator	7	Silent Alarm	22
Off Indicator	7	STAY Indicator	6
On Indicator	7	STAY Mode 1	8, 22
STAY Indicator	6	Entry Guard Timer	8
System Disarmed	6	STAY Mode 2	8, 22
Zone Indicators	5	Entry Guard Timer	9
Communciation Fail	14	Programming Zones	9
Date and Time	14	Strobe Test	16
Day Alarm	17	System Disarmed	6
Detectors	20	Tamper Alarm	12
Disarmed	20	Telco Arm Sequence	15, 22
Disarming	9	Telco Disarm Sequence	22
Domestic Dialing		Telephone Line Fail	14
Acknowledging Domestic Calls	17	Test Report	16
Disable	18	Testing	
Programming Domestic Telephone Numbers	18	Bell Test	16
Duress Alarm	11	Horn Speaker Test	16
EEPROM Fault	14	Strobe Test	16
Entry Delay/Entry Time	20	Test Report	16
Entry Guard Timer	8, 9	Walk Test	16
Event Memory Recall	16	Unsealed	22
External Equipment	20	User Codes	9, 10, 22
Fault Analysis	14	Radio Users	9
Fault Description		Walk Test	16
AC Mains Fail	14	Zone Indicators	5
AUX Power Supply Fail	14	Zones	22

© 2008 Bosch Security Systems, Inc.
F01U089400-02



BOSCH